

Gas Piping Layout

Schematic Component Diagrams

C000504

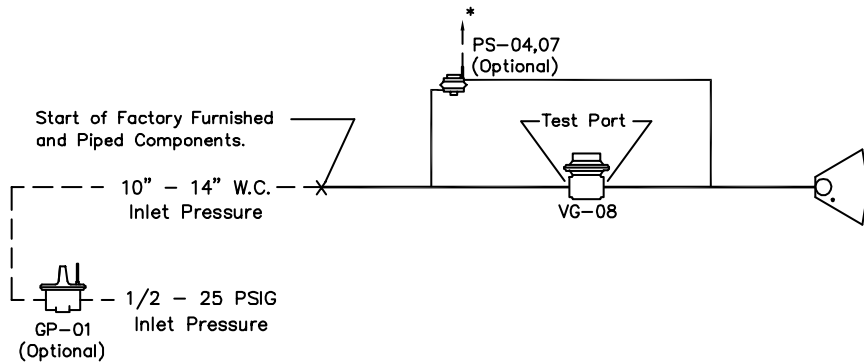

2 STAGE GAS TRAIN UP TO 329 MBH

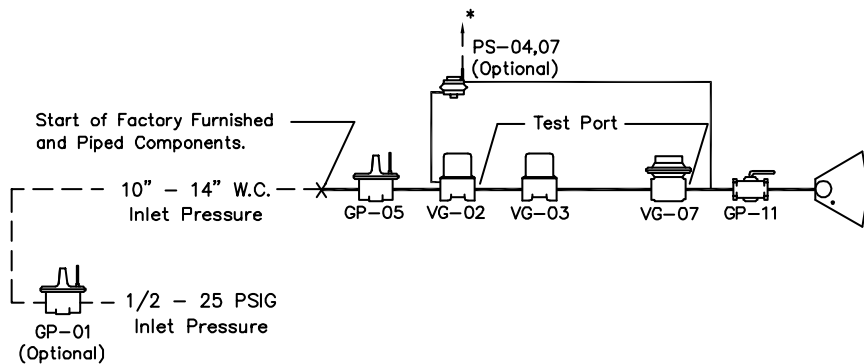

MODULATING GAS TRAIN UP TO 950 MBH

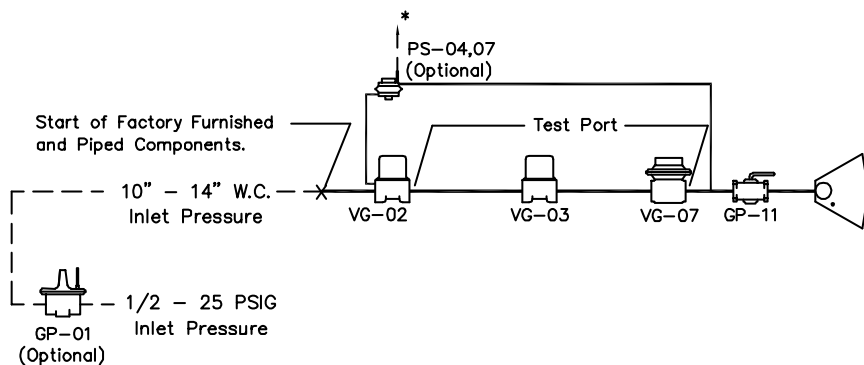

MODULATING GAS TRAIN OVER 950 MBH

COMPONENT IDENTIFICATION

GP-01 HIGH GAS PRESSURE REGULATOR
 GP-05 MAIN GAS PRESSURE REGULATOR
 GP-11 MAIN GAS SHUT-OFF VALVE

VG-02 MAIN GAS VALVE
 VG-03 AUXILIARY GAS VALVE
 VG-07 MODULATING VALVE
 VG-08 HIGH-LOW-OFF GAS VALVE

PS-04 LOW GAS PRESSURE SWITCH
 PS-07 HIGH GAS PRESSURE SWITCH

NOTES:

1. Vent limiting devices provided wherever possible, when venting is required the venting to outside is by others on indoor units and furnished by factory on outdoor units.
2. For inlet pressures under 10" W.C. - Please consult factory.
3. The standard ETL listed unit meets ANSI, FM and IRI requirements. Note that units with an A200 option are not ETL listed and therefore do not meet FM and IRI requirements.