

DAT SERIES AIR TURNOVER SYSTEMS

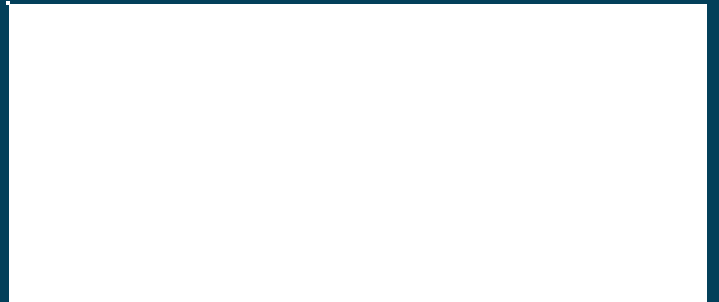

Capacities: 10,000—150,000 CFM



DAT Series Air Turnover Systems

Selecting and sizing a DAT is dependent on the required air rotations, building heat load, exhaust air levels and any fresh air requirements.

AIR ROTATIONS

Proper air rotation is the key to ensuring a minimal temperature gradient throughout the building and a successful air turnover system. The type of building, its size and the percentage of occupied space will also effect the required air volume. An empty building will require more air movement than a similar sized building with space occupied by machines and storage.

BUILDING HEAT LOAD

The building heat load is a result of transmission losses, infiltration losses and ventilation loads.

Transmission losses are the conduction heat losses through the building roof, walls and floor.

Infiltration losses are the heat loads due to air leakage into and out of the building. All buildings have some leakage but newer ones are generally tighter. The frequency of doors opening will also affect these levels.

Ventilation loads are the heat requirements due to exhaust air. Any air that is exhausted will have an equal amount of air entering the building to replace it. This air will enter at the outdoor temperature and require heating. If a properly sized make-up air unit is working in conjunction with the exhauster, this heat load may not be required by the DAT.

FRESH AIR QUANTITIES

The DAT Series is capable of handling up to 20% fresh air with propeller fans and higher with centrifugal fans. This can be used as make-up for exhaust air or to provide a slight positive pressure in the building. When calculating heat loads due to ventilation, use the higher of the DAT's fresh air quantity and any exhaust air which does not have a make-up air unit working in conjunction with it.

Selection Guide

DESIGN CONDITIONS

Winter Design Temp. (TW) _____

Wall Insulation (RW) _____

Indoor Building Temp. (TI) _____

Roof Insulation (RR) _____

Building Dimensions – L x W x H _____

BUILDING SKETCH

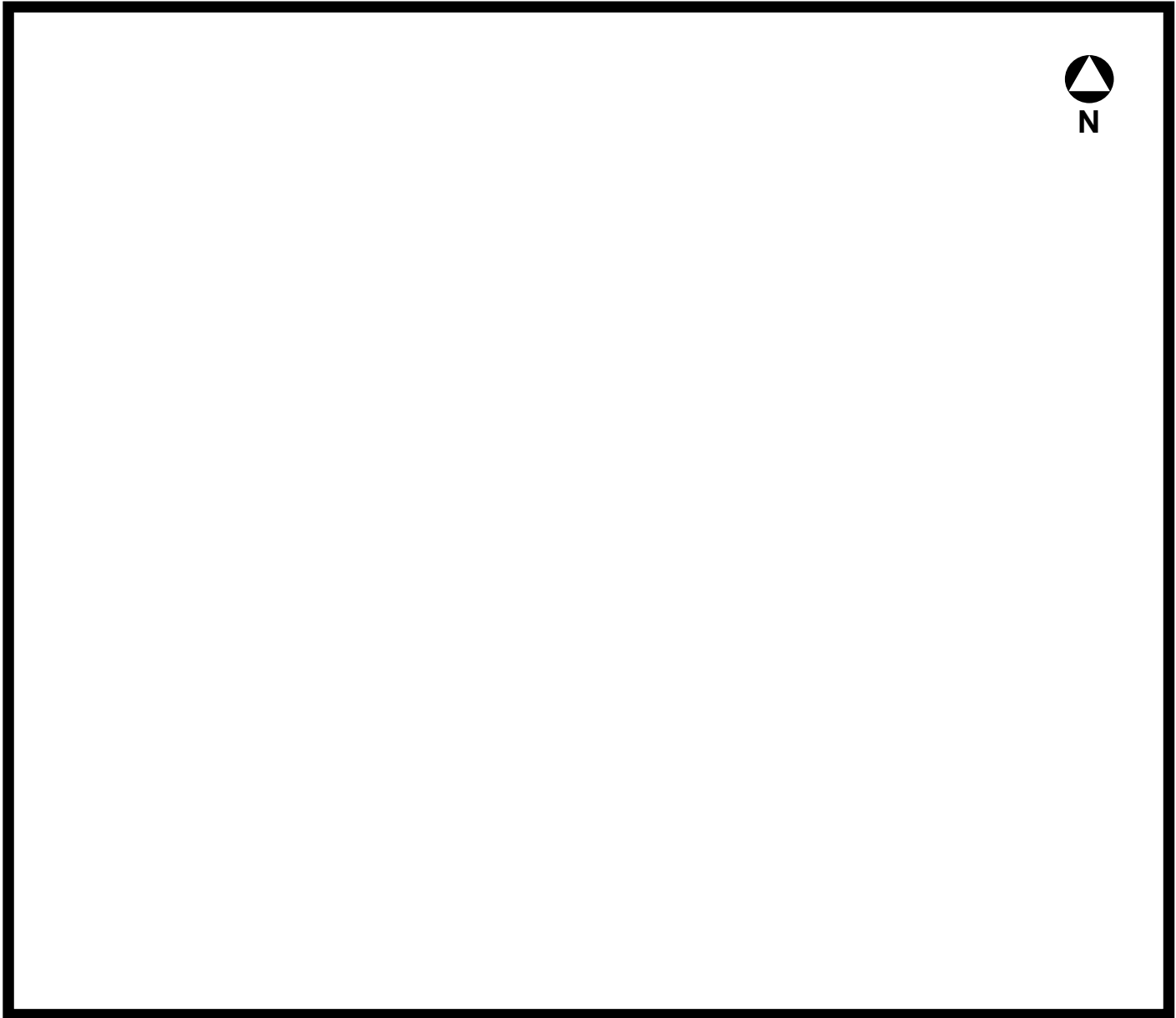
A large, empty rectangular box with a thick black border, intended for a building sketch. In the top right corner of this box, there is a north arrow symbol consisting of a circle with a triangle pointing upwards and the letter 'N' below it.

- I) Show Door Location and Sizes
 - II) Show Location and Airflow of Exhaust Fans
 - III) Show Racking, Internal Partitions Machinery, Contaminated Areas etc.
-

DAT Series Air Turnover Systems

AIRFLOW REQUIREMENTS

The required DAT SCFM is based on building volume (BV), percentage of building occupied with storage, machines, etc. (% full) and the required air rotations per hour (ARH).

$$\text{DAT SCFM} = \text{ARH} \times \text{BV} \times \% \text{OPEN} / 60$$

Where $\text{BV} = \text{L} \times \text{W} \times \text{H}, \text{FT.}^3$

$\% \text{OPEN} = 100\% - \% \text{FULL}$

ARH = See Table 2

BUILDING HEAT LOAD CALCULATIONS

A. Transmission Losses

| | AREA (FT. ²) | | 1/R | | BTUH/°F |
|-----------------------------------|--------------------------|---|----------------------|---|---------|
| 1) Windows, Doors | _____ | x | 1.13 | = | _____ |
| 2) Slab Floor, FT. ^(a) | _____ | x | 0.10 | = | _____ |
| 3) Basement Walls | _____ | x | 0.20 | = | _____ |
| 4) Walls | _____ | x | _____ ^(b) | = | _____ |
| 5) Roof | _____ | x | _____ ^(b) | = | _____ |
| 6) Total | | | | | _____ |

(a) Perimeter of building walls exposed to outside (feet).

(b) Resistance (R) for walls and roof = 3.5 x insulation thickness (inches).

$$\text{Transmission Heat Loss} = \text{Total} \times (\text{TI} - \text{TW}) = \text{_____ BTUH}$$

B. Infiltration Losses

$$\text{Infiltration Heat Loss} = \text{L} \times \text{W} \times \text{H} \times \text{AC} \times 0.018 \times (\text{TI} - \text{TW}) = \text{_____ BTUH}$$

Where L, W, and H are building dimensions in feet and AC is the infiltration air changes (see Table 1).

C. Ventilation Losses

$$\text{Ventilation Heat Loss} = \text{SCFM} \times 1.08 \times (\text{TI} - \text{TW}) = \text{_____ BTUH}$$

$$\text{D. Total Heat Loss (A + B + C)} \quad \text{_____ BTUH}$$

TABLE 1: NATURAL INFILTRATION AIR CHANGES

TABLE 1A: AIR CHANGES PER HOUR DUE TO NATURAL INFILTRATION FOR AVERAGE BUILDING CONSTRUCTION

| Size of Building (FT ²) Excluding Offices, Cafeteria etc. | Closed Door | Average Door Operation | | Above Avg. Door Operation | |
|---|----------------|------------------------|--------------------|---------------------------|--------------------|
| | | Indoor Docking | Outdoor Docking | Indoor Docking | Outdoor Docking |
| 5,000 – 10,000 | 1.5 – 2.5 | 1.5 – 2.5 | 1.5 – 3.0 | 2.0 – 4.0 | 2.5 – 5.0 |
| 10,000 – 20,000 | 0.7 – 1.3 | 1.2 – 2.0 | 1.5 – 2.5 | 2.0 – 3.5 | 2.0 – 4.0 |
| 20,000 – 40,000 | 0.7 – 1.0 | 1.0 – 1.5 | 1.2 – 2.0 | 1.5 – 3.0 | 1.8 – 3.5 |
| 40,000 – 100,000 | 0.5 – 0.8 | 0.7 – 1.3 | 1.0 – 1.5 | 1.0 – 2.0 | 1.3 – 2.0 |
| 100,000 – 200,000 | 0.3 – 0.5 | 0.5 – 0.8 | 0.5 – 1.0 | 0.7 – 1.3 | 0.8 – 1.5 |
| 200,000 – 500,000 | 0.3 – 0.4 | 0.4 – 0.7 | 0.5 – 0.8 | 0.7 – 1.0 | 0.7 – 1.5 |

TABLE 1B: AIR CHANGES PER HOUR DUE TO NATURAL INFILTRATION FOR TIGHT BUILDING CONSTRUCTION

| Size of Building (FT ²) Excluding Offices, Cafeteria etc. | Closed Door | Average Door Operation | | Above Avg. Door Operation | |
|---|----------------|------------------------|--------------------|---------------------------|--------------------|
| | | Indoor Docking | Outdoor Docking | Indoor Docking | Outdoor Docking |
| 5,000 – 10,000 | 0.8 – 1.5 | 1.5 – 2.5 | 1.5 – 3.0 | 2.0 – 4.0 | 2.5 – 5.0 |
| 10,000 – 20,000 | 0.7 – 1.0 | 1.3 – 2.0 | 1.5 – 2.5 | 2.0 – 3.5 | 2.0 – 4.0 |
| 20,000 – 40,000 | 0.5 – 0.8 | 1.0 – 1.3 | 1.3 – 2.0 | 1.5 – 3.0 | 1.8 – 3.5 |
| 40,000 – 100,000 | 0.3 – 0.5 | 0.7 – 1.0 | 1.0 – 1.3 | 1.0 – 1.5 | 1.0 – 2.0 |
| 100,000 – 200,000 | 0.3 – 0.5 | 0.5 – 0.7 | 0.7 – 1.0 | 0.7 – 1.0 | 0.7 – 1.3 |
| 200,000 – 500,000 | 0.3 – 0.4 | 0.3 – 0.5 | 0.5 – 0.7 | 0.5 – 0.8 | 0.5 – 1.0 |

Tables based on:

- A) Wall aspect ratio not greater than 5:1
- B) Balanced exhaust and make-up air quantities
- C) Exposure on four sides less a minimum allowance for an adjoining office.
- D) Floor to roof deck height of 18 FT.

Notes:

- 1) Average Construction: Masonry walls with up to 30% continuous sash
- 2) Tight Construction: Windowless brick and block or windowless insulated metal siding
- 3) Closed Door Operation: Night, weekend, off-shift or on shift with doors operated at greater than 1 hr. intervals
- 4) Average Door Operation: Doors open briefly up to 2 times per hour
- 5) Above Average Door Operation: Doors open up to 4 times per hour

TABLE 2: RECOMMENDED ARH VALUES

| Application | ARH Value |
|-----------------|-----------|
| Warehouse | 1.5 – 2.5 |
| Manufacturer | 2.0 – 3.0 |
| Aircraft Hanger | 2.5 – 3.5 |

DAT Series Air Turnover Systems

EXAMPLE:

Given the building layout below, size the DAT's to handle the airflow and heat requirements. The new warehouse is 25% full with storage and the manufacturing facility is 10% full. This is a new building with tight construction, closed doors in the manufacture area and average door use in the warehouse.

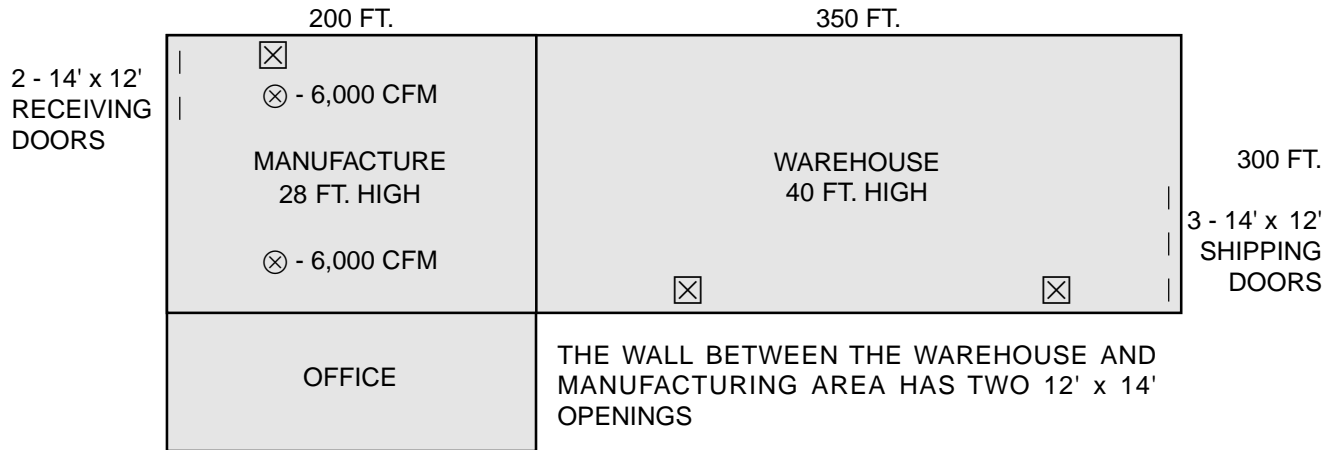

| | | | |
|-----------------------|------|----------------------|------------------|
| Winter Design (TW) | 0°F | Wall Insulation (RW) | 10.5 (3" x 3.5") |
| Manu. Area Temp. (TW) | 68°F | Roof Insulation (RR) | 14 (4" x 3.5") |
| Warehouse Temp. (TI) | 62°F | | |

Treat each section separate, first the manufacturing area.

DAT SCFM REQUIREMENTS

A manufacturing area requires 2 to 3 air rotations per hour (see Table 2 for ARH values). Use 2.0 to determine the minimum allowable air flow. Given 10% full, the % open area is 90%.

$$\text{DAT SCFM} = 2.0 \times 200 \times 300 \times 28 \times 0.9/60 = 50,400 \text{ SCFM}$$

Selecting a DAT 300 (see Table 3A), the airflow can be set at 55,000 SCFM and will provide 2.2 air rotations per hour. With the fresh air option, 11,000 SCFM of fresh air (20% of 55,000) can be introduced.

The symbol ☒ on the building footprint shows the recommended DAT locations. Both receiving and shipping doors have a DAT nearby so that any incoming cold air can be heated quickly.

BUILDING HEAT LOAD CALCULATIONS

A. Transmission Losses

| | AREA (FT. ²) | | 1/R | | BTUH/°F |
|-------------------|--------------------------|---|--------|---|--------------|
| 1) Windows, Doors | 2 x 12 x 14 | x | 1.13 | = | 400 |
| 2) Slab Floor, | 200 + 300 | x | 0.10 | = | 500 |
| 3) Basement Walls | 0 | x | 0.20 | = | 0 |
| 4) Walls | 28 x 500 | x | 1/10.5 | = | 1,350 |
| 5) Roof | 200 x 300 | x | 1/14 | = | 4,300 |
| 6) Total | | | | | 6,500 |

$$\text{Transmission Heat Load} = 6,500 \times (68 - 0) = \mathbf{445,400 \text{ BTUH}}$$

B. Infiltration Losses

First, the required air change (AC) must be determined. To do this calculate the floor size and determine AC from Table 1. The floor space is 60,000 FT.² (200 x 300) and given tight building construction with closed doors, from Table 1B, AC ranges from 1/2 to 3/4. Use 1/2.

$$\text{Infiltration Heat Load} = 200 \times 300 \times 28 \times 0.5 \times 0.018 \times (68 - 0) = \mathbf{1,028,200 \text{ BTUH}}$$

C. Ventilation Losses

Base this value on the two 6,000 SCFM exhausters since this is greater than the 11,000 SCFM of fresh air.

$$\text{Ventilation Heat Load} = 12,000 \times 1.08 \times (68 - 0) = \mathbf{881,300 \text{ BTUH}}$$

D. Total Heat Loss (A + B + C)

2,354,900 BTUH

Thus the unit will be a **DAT 300-GTM250** with **2,500,000 BTUH** heat output.

The following table summarizes the warehouse calculations. The units were provided with 10% fresh air to help pressurize the warehouse area and keep any dust from manufacturing in the other room.

| | |
|---------------------------|----------------------------------|
| Minimum Air Rotations | 1.5 |
| Minimum SCFM | 78,800 SCFM |
| DAT SCFM | 2 @ 40,000 SCFM each |
| Total Transmission Losses | 10,840 BTUH °F. FT. ² |
| Transmission Heat Load | 672,100 BTUH |
| Infiltration Heat Load | 1,640,500 BTUH |
| Ventilation Heat Load | 562,500 BTUH |
| DAT Heat Output | 2 @ 1,500,000 BTUH each |
| DAT Model | DAT 250-GTDM150 |

WHY USE THE DAT SERIES?

LOWER ENERGY COSTS

- Even air temperatures brings heat from the roof to the employee level. Lower ceiling temperatures reduce heat losses through the roof. Smaller floor to ceiling temperature gradient reduces infiltration losses further lowering fuel consumption.
- High efficiency propeller fans reduce electrical costs by up to 40%.
- Smooth internal wall construction eliminates obstructive internal seams. This minimizes air flow restrictions and further reduces energy consumption.
- Temprite's Electronic Controls (TEC) systems provide energy savings through programmable temperature set backs for night and weekend periods.

LOWER INSTALLATION/MAINTENANCE COSTS

- One power and one fuel hook up minimize installation work
- No duct work required.
- No structural support for roof mounted units.
- No expensive helicopter or crane lifts.
- All maintenance done at floor level, no special equipment needed.

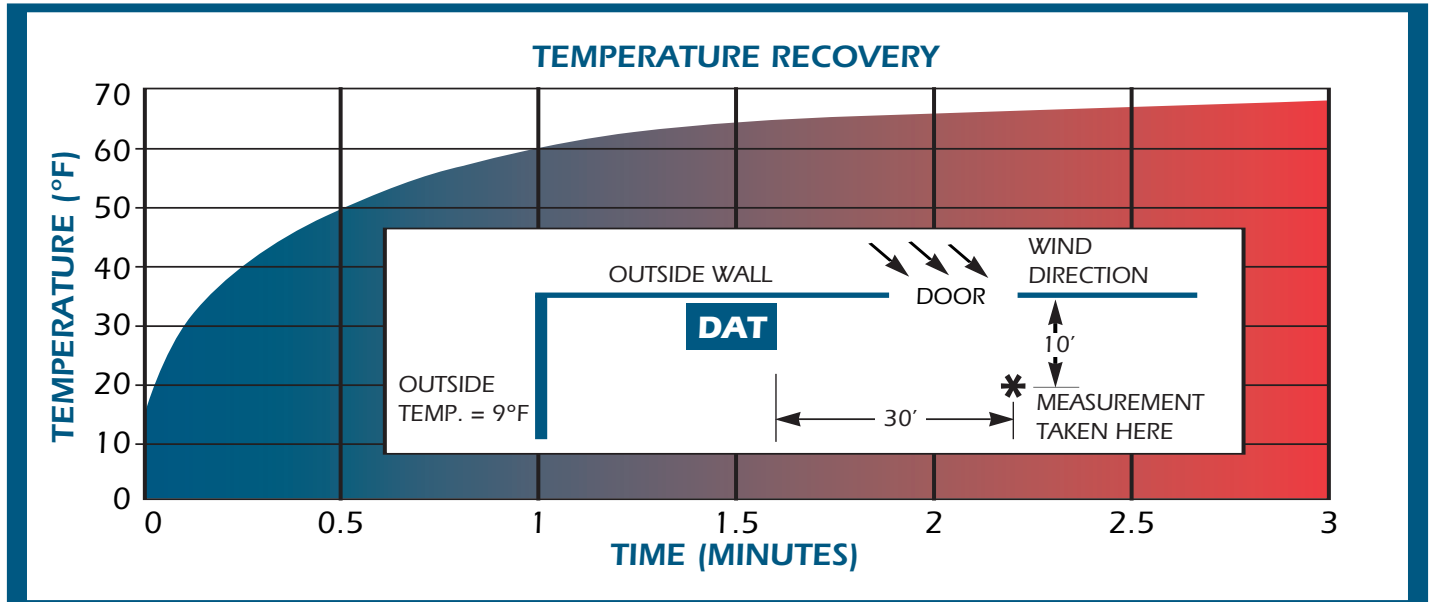

IMPROVE EMPLOYEE COMFORT

- High air volumes eliminate stratification and hot and cold areas, thus giving a constant environment throughout the plant.
- DAT's placed near shipping doors will entrain incoming cold air. Roof top heaters must try to heat the space from above, away from the cold air. Thus, the DAT will provide much faster temperature recovery after the door is shut (see above graph).

DAT SERIES

AIR TURNOVER SYSTEMS

WHAT IS AIR TURNOVER?

An Air Turnover System is a floor mounted system utilizing high air volumes with low temperature rises to heat buildings.

TEMPRITE'S Air Turnover System, the DAT SERIES, is designed to provide excellent temperature uniformity in high bay manufacturing and warehouse facilities. This system works best in buildings 18 to 60 feet high.

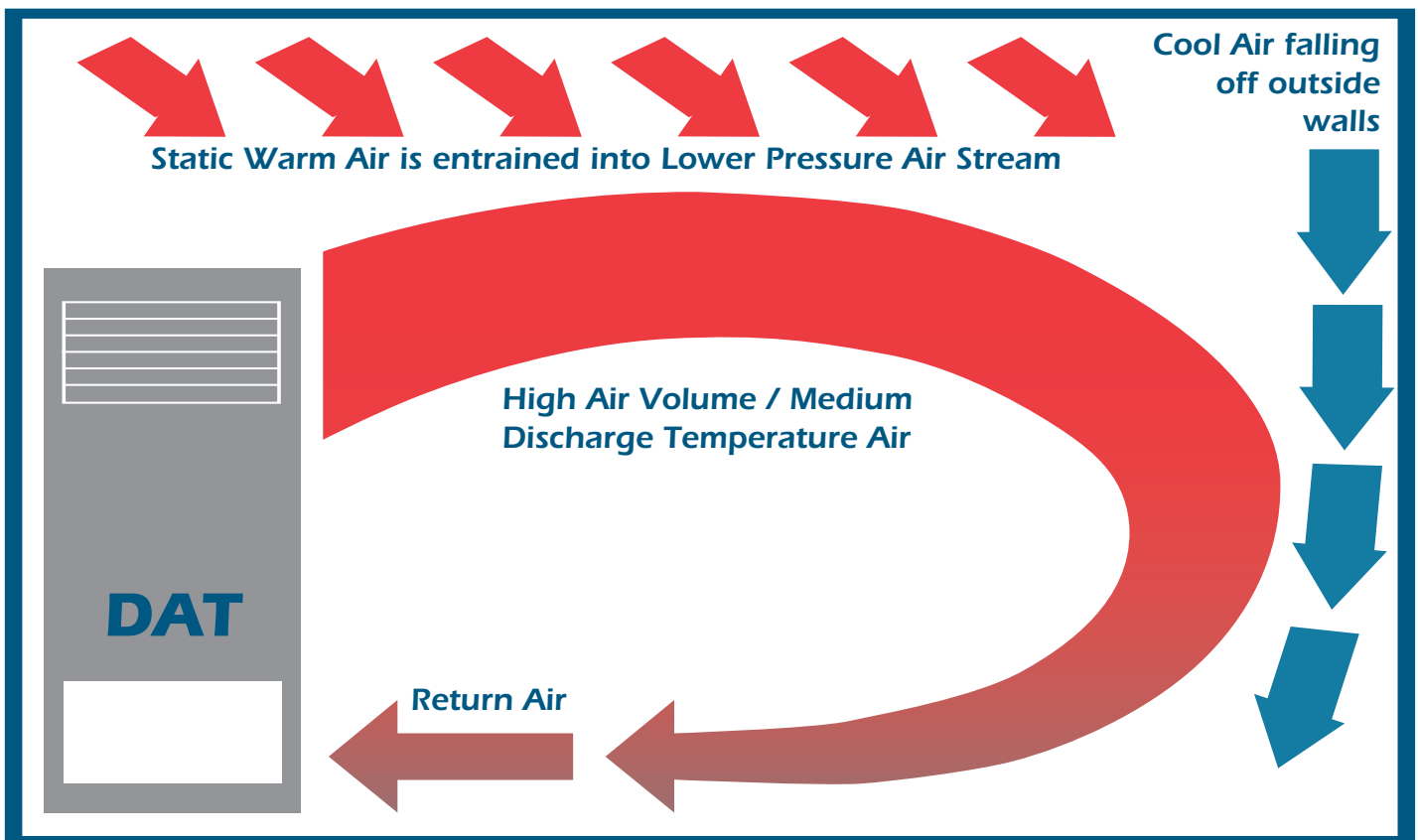

HOW DOES THE DAT SERIES WORK?

The DAT SERIES is designed with return air at the floor level and discharge air near the ceiling level. The continuous high air volume moved by the DAT will provide excellent temperature uniformity. Warm static air near the roof line is entrained into the high air volume. Likewise, cold air around the building perimeter is entrained and eliminated.

A traditional 'Forced' air heater cannot provide these benefits because it provides low air flow at high discharge temperatures. Without high air volumes, entrainment is minimal. Also, forced air heaters are located at the roof line, away from the incoming cold air, and this slows temperature recovery at the floor level.

DAT Series Air Turnover Systems

Casing Construction

WALLS AND BASE

Temprite's DAT Series is designed with a smooth interior surface which provides lower pressure drops, lower fan horsepower and quieter operation.

Maximum panel widths of 24" and the double break provide a rigid construction which prevents bulging (oil canning) during startup.

Walls are constructed from 16 gauge galvanized steel and assembled with zinc plated 1/4" bolt and nuts. The channel base is constructed from reinforced 10 gauge galvanized steel and assembled with 3/8" bolt and nuts.

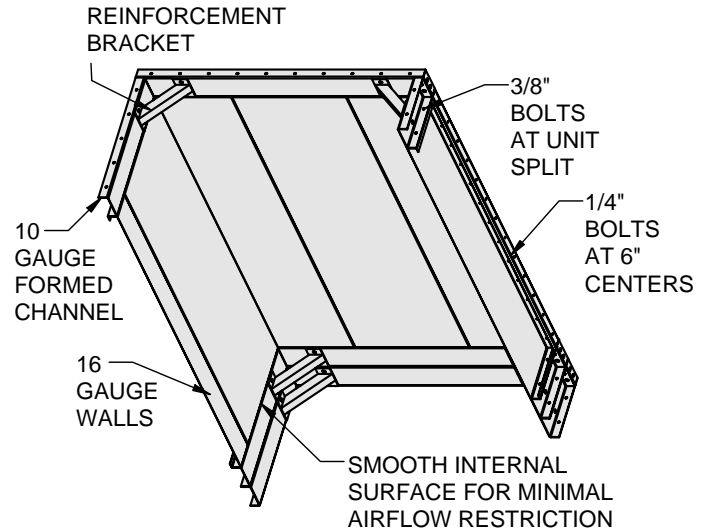

AIR RETURN AND SUPPLY

The intake and discharge plenums are made of panel construction for greater rigidity when compared to conventional screen plenums. Diffuser holes are computer designed and manufactured with a CNC (Computerized Numerical Control) machine for minimal pressure resistance.

Intake and discharge plenums are available with three or four sided openings.

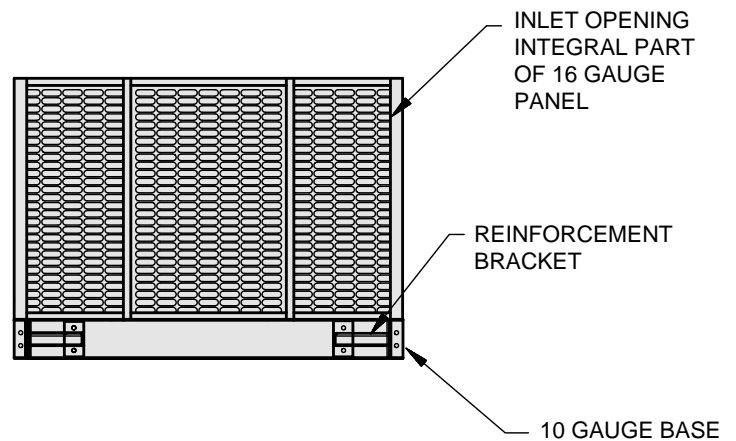

ACCESS DOORS

Component maintenance is easy with the hinged access doors. Each door is complete with a continuous piano hinge, handle and two captive screw fasteners.

The welded frames and panel style construction result in a rigid door.

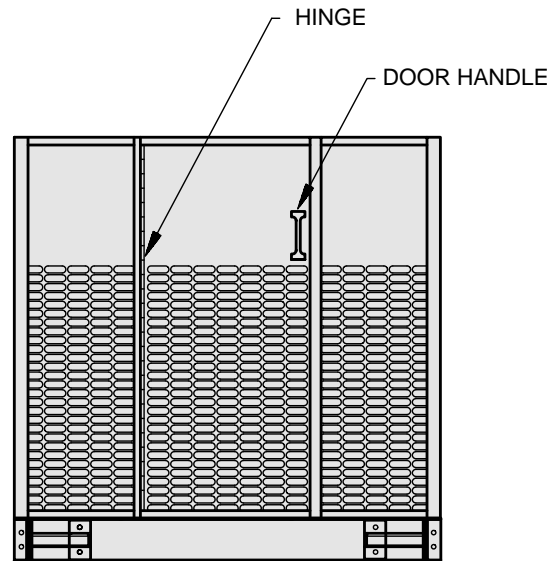

SHIPPING SPLITS

Designed for simple field assembly, mating flanges are built of heavy gauge formed channel with matching holes. All mounting hardware is provided.

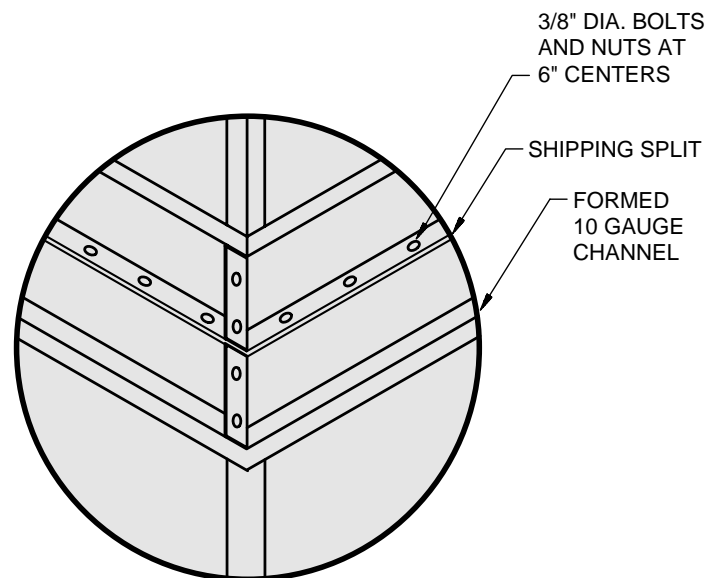

DAT Series Air Turnover Systems

Fan Assemblies

PROPELLER FANS

The most energy efficient and cost efficient solution is Temprite's low sound heavy duty propeller fans. Each is complete with long lasting pillow block bearings, adjustable drives and adjustable motor base.

Motors are available as ODP, TEFC, Standard and/or Premium Efficiency.

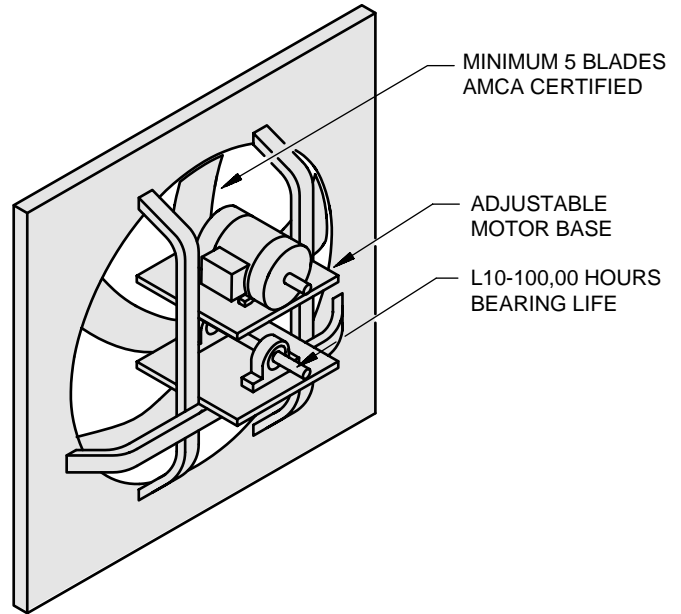

CENTRIFUGAL FANS

When higher statics from filters, dampers ductwork, etc. exists, use the AMCA rated forward curved centrifugal fans. Each is complete with heavy duty shaft, pillow block bearings, shaft coupling and belt drives.

These Fans are designed for low rpm and low noise levels.

Motors are available as ODP, TEFC, Standard and/or Premium Efficiency.

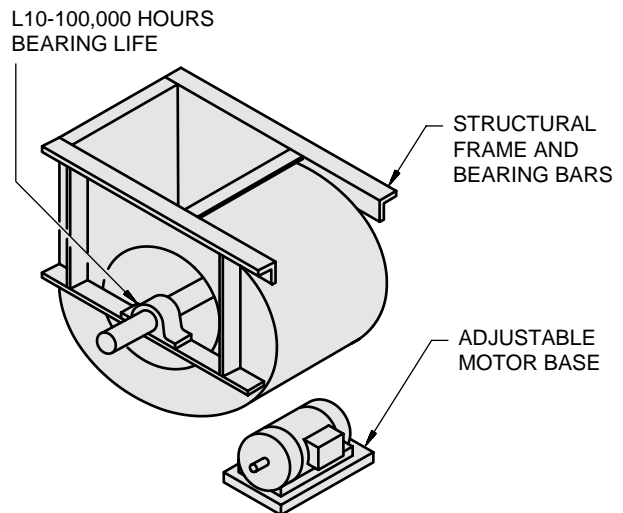

Combustion Section

CHAMBER

Temprite's TDM chamber is one of the most energy efficient (80%+) on the market. Long life has been ensured by designing the chamber for skin temperatures not to exceed 75% of the scaling temperature.

The secondary tubes incorporate a two pass arrangement for higher efficiency and long lasting performance. The primary chamber is 409 stainless. The secondary tubes are heavy gauge boiler tubes with an option for 409 stainless.

This is all backed by the standard 10 year non-prorated warranty.

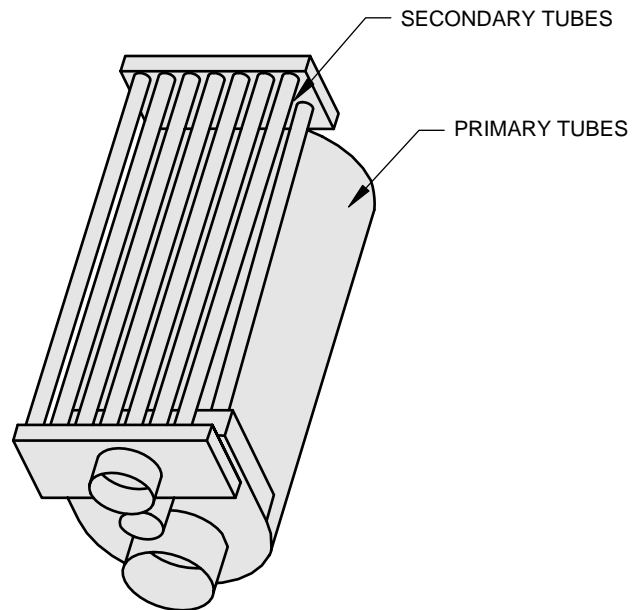

BURNER AND I.D. FANS

Power type burners, complete with all safety controls, CSA, UL and ULC approved. Full modulation natural gas burners with up to 4 to 1 turndown. Propane or no. 2 light oil burners are also available.

Best heating performance is obtained with a slightly negative chamber. The Induced Draft (I.D.) fan with manual damper and locking quadrant allows for field set up for the exact operating conditions.

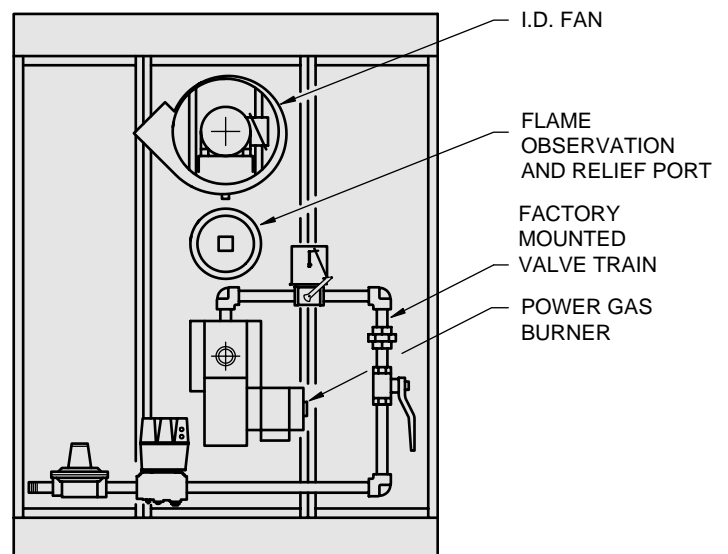

DAT Series Air Turnover Systems

Controls

ELECTRO-MECHANICAL

All Temprite units are complete with full safety controls and electro-mechanical temperature controls.

Mounted in a NEMA 1 (option - NEMA 12) panel is the motor starter, fuses, overloads, control transformer and controls. On the panel face is the disconnect switch, on/off switch and indicating lights.

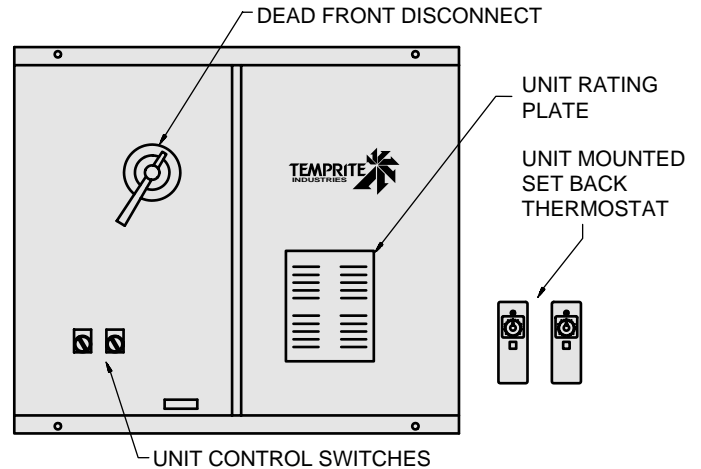

TEC CONTROL

Improved energy conservation is achieved with Temprite's electronic controls (TEC) package. This programmable controller has temperature set back, building pressure control, mixed air control and on multiple unit applications, staggered firing to provide maximum efficiency.

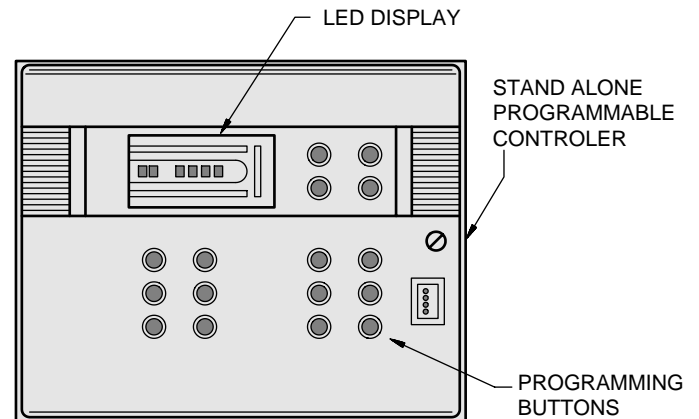

Options

DAMPERS

Low leakage parallel blade type with 16 gauge galvanized blades and frame, sealed bearings and coated steel shafts provide long life and reliability for manual and automatic operation.

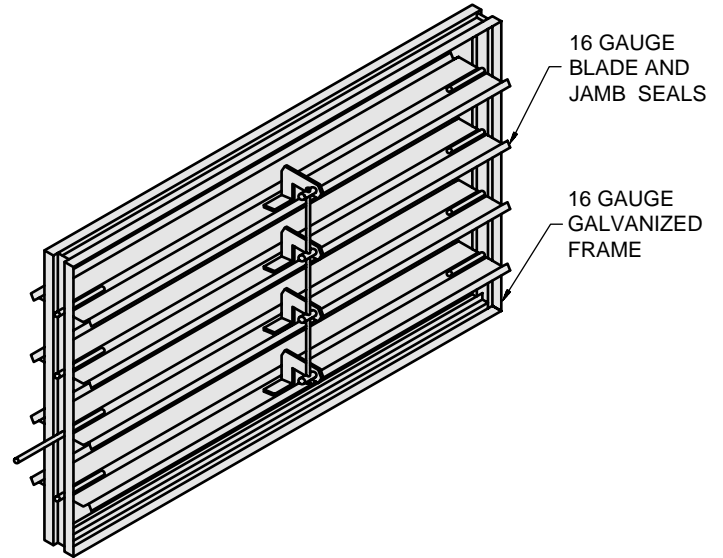

FILTERS

1" washable media filters and 2" disposable filters are available. Filters are mounted flat in racks at the return air openings or in a V-bank arrangement.

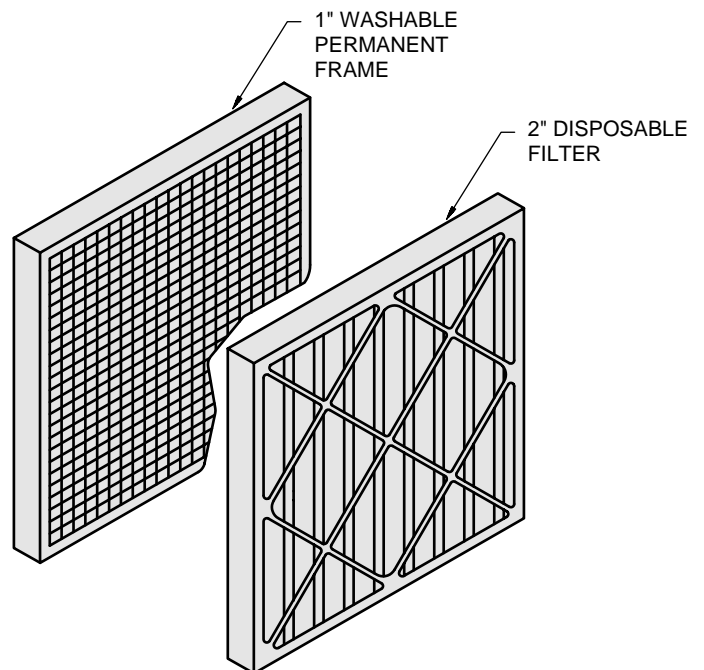

DAT Series Air Turnover Systems

DAT Performance Tables

TABLE 3A: PERFORMANCE WITH PROPELLER FANS

| Model No. | SCFM | Fan Quantity and Size | Fan HP | | Heater Output, MBTUH | | | Temperature Rise, °F | | |
|-------------|---------|-----------------------|------------|--------------|----------------------|----------|----------|----------------------|----------|----------|
| | | | No Filters | With Filters | Option 1 | Option 2 | Option 3 | Option 1 | Option 2 | Option 3 |
| 75 | 8,000 | 2-24" | 1/2 | 3/4 | 400 | 500 | 550 | 46 | 58 | 64 |
| | 10,000 | 2-24" | 3/4 | 3/4 | 400 | 500 | 550 | 37 | 46 | 51 |
| | 12,000 | 2-24" | 1 | 1 | 400 | 500 | 550 | 31 | 39 | 42 |
| | 14,000 | 2-24" | 1 | N/A | 400 | 500 | 550 | 26 | 33 | 36 |
| 100 | 14,000 | 2-30" | 3/4 | 1 | 650 | 750 | — | 43 | 50 | — |
| | 18,000 | 2-30" | 1 | 1-1/2 | 650 | 750 | — | 33 | 39 | — |
| | 20,000 | 2-30" | 1-1/2 | 1-1/2 | 650 | 750 | — | 30 | 35 | — |
| | 24,000 | 2-30" | 2 | 3 | 650 | 750 | — | 25 | 29 | — |
| | 28,000 | 2-30" | 3 | 3 | 650 | 750 | — | 21 | 25 | — |
| 175 | 20,000 | 2-36" | 1 | 1-1/2 | 850 | 1000 | — | 39 | 46 | — |
| | 24,000 | 2-30" | 1-1/2 | 2 | 850 | 1000 | — | 33 | 39 | — |
| | 30,000 | 2-30" | 2 | 3 | 850 | 1000 | — | 26 | 31 | — |
| | 35,000 | 2-30" | 3 | 3 | 850 | 1000 | — | 22 | 26 | — |
| 250 | 30,000 | 2-42" | 1-1/2 | 2 | 1250 | 1500 | 1750 | 39 | 46 | 54 |
| | 35,000 | 2-42" | 2 | 3 | 1250 | 1500 | 1750 | 33 | 40 | 46 |
| | 40,000 | 2-42" | 3 | 3 | 1250 | 1500 | 1750 | 29 | 35 | 41 |
| | 45,000 | 2-42" | 3 | 5 | 1250 | 1500 | 1750 | 26 | 31 | 36 |
| | 50,000 | 2-42" | 5 | 5 | 1250 | 1500 | 1750 | 23 | 28 | 32 |
| 300 | 40,000 | 2-48" | 2 | 3 | 2000 | 2500 | — | 46 | 58 | — |
| | 45,000 | 2-48" | 3 | 5 | 2000 | 2500 | — | 41 | 51 | — |
| | 50,000 | 2-48" | 3 | 5 | 2000 | 2500 | — | 37 | 46 | — |
| | 55,000 | 2-48" | 3 | 5 | 2000 | 2500 | — | 34 | 42 | — |
| | 60,000 | 2-48" | 5 | 7-1/2 | 2000 | 2500 | — | 31 | 39 | — |
| | 65,000 | 2-48" | 5 | 7-1/2 | 2000 | 2500 | — | 28 | 36 | — |
| | 75,000 | 2-48" | 7-1/2 | N/A | 2000 | 2500 | — | 25 | 31 | — |
| 400 | 50,000 | 2-54" | 3 | 5 | 2500 | 2750 | — | 46 | 51 | — |
| | 60,000 | 2-54" | 5 | 5 | 2500 | 2750 | — | 39 | 42 | — |
| | 70,000 | 2-54" | 7-1/2 | 7-1/2 | 2500 | 2750 | — | 33 | 36 | — |
| | 80,000 | 2-54" | 7-1/2 | 10 | 2500 | 2750 | — | 29 | 32 | — |
| | 85,000 | 2-54" | 10 | 10 | 2500 | 2750 | — | 27 | 30 | — |
| 600 | 60,000 | 2-60" | 3 | 5 | 3000 | 3500 | 4000 | 46 | 54 | 62 |
| | 70,000 | 2-60" | 5 | 7-1/2 | 3000 | 3500 | 4000 | 40 | 46 | 53 |
| | 80,000 | 2-60" | 7-1/2 | 7-1/2 | 3000 | 3500 | 4000 | 35 | 41 | 46 |
| | 90,000 | 2-60" | 7-1/2 | 10 | 3000 | 3500 | 4000 | 31 | 36 | 41 |
| | 100,000 | 2-60" | 10 | 10 | 3000 | 3500 | 4000 | 28 | 32 | 37 |
| | 110,000 | 2-60" | 10 | N/A | 3000 | 3500 | 4000 | 25 | 29 | 34 |
| 600S | 90,000 | 3-60" | 3 | 5 | 5000 | 5500 | 6000 | 51 | 57 | 62 |
| | 100,000 | 3-60" | 5 | 5 | 5000 | 5500 | 6000 | 46 | 51 | 56 |
| | 120,000 | 3-60" | 7-1/2 | 7-1/2 | 5000 | 5500 | 6000 | 39 | 42 | 46 |
| | 140,000 | 3-60" | 7-1/2 | 10 | 5000 | 5500 | 6000 | 33 | 36 | 40 |
| | 150,000 | 3-60" | 10 | 10 | 5000 | 5500 | 6000 | 31 | 34 | 37 |

The quantity of motors is equivalent to the quantity of fans.

N/A = Not Available.

DAT Series Air Turnover Systems

HEATER SIZES

| Heater Model Number | Heat Output MBTUH | Gas Valve Train Size, in. npt | | Stack Diameter | Induced Draft Fan HP | Burner Motor HP |
|---------------------|-------------------|-------------------------------|----------|----------------|----------------------|-----------------|
| | | 7" W.C. | 14" W.C. | | | |
| TDM 40 | 400 | 1 | 3/4 | 8 | 1/3 | 1/8 |
| TDM 50 | 500 | 1 | 3/4 | 8 | 1/3 | 1/4 |
| TDM 55 | 550 | 1 | 1 | 8 | 1/3 | 1/3 |
| TDM 65 | 650 | 1-1/4 | 1 | 10 | 1/3 | 1/3 |
| TDM 75 | 750 | 1-1/4 | 1 | 10 | 1/3 | 1/3 |
| TDM 85 | 850 | 1-1/4 | 1 | 10 | 1/2 | 1/3 |
| TDM 100 | 1000 | 1-1/2 | 1 | 10 | 1/2 | 1/3 |
| TDM 125 | 1250 | 1-1/2 | 1-1/4 | 12 | 3/4 | 1/2 |
| TDM 150 | 1500 | 2 | 1-1/2 | 12 | 3/4 | 1/2 |
| TDM 175 | 1750 | 2 | 1-1/2 | 12 | 1-1/2 | 1/2 |
| TDM 200 | 2000 | 2 | 1-1/2 | 12 | 1-1/2 | 1/2 |
| TDM 250 | 2500 | 2 | 2 | 12 | 2 | 1 |
| TDM 275 | 2750 | 2-1/2 | 2 | 14 | 2 | 1 |
| TDM 300 | 3000 | 2-1/2 | 2 | 14 | 3 | 1 |
| TDM 350 | 3500 | 3 | 2 | 14 | 3 | 1-1/2 |
| TDM 400 | 4000 | 3 | 2-1/2 | 14 | 3 | 2 |
| TDM 500 | 5000 | 3 | 2-1/2 | 16 | 3 | 3 |
| TDM 550 | 5500 | 3 | 2-1/2 | 16 | 5 | 3 |
| TDM 600 | 6000 | 3 | 2-1/2 | 16 | 5 | 5 |

All induced draft fan motors are 1800 RPM except TDM 125 & 150 which are 1200 RPM.

HIGH PRESSURE REGULATORS

| Heater Model Number | Regulator Inlet Size, in. npt | | | | |
|---------------------|-------------------------------|--------|---------|---------|---------|
| | 2 Psig | 5 Psig | 10 Psig | 15 Psig | 30 Psig |
| TDM 40 | 1 | 3/4 | 3/4 | 3/4 | 3/4 |
| TDM 50 | 1-1/2 | 1 | 1 | 1 | 3/4 |
| TDM 55 | 1-1/2 | 1 | 1 | 1 | 3/4 |
| TDM 65 | 1-1/2 | 1 | 1 | 1 | 1 |
| TDM 75 | 1-1/2 | 1-1/2 | 1 | 1 | 1 |
| TDM 85 | 1-1/2 | 1-1/2 | 1 | 1 | 1 |
| TDM 100 | 1-1/2 | 1-1/2 | 1-1/2 | 1-1/2 | 1-1/2 |
| TDM 125 | 1-1/2 | 1-1/2 | 1-1/2 | 1-1/2 | 1-1/2 |
| TDM 150 | 1-1/2 | 1-1/2 | 1-1/2 | 1-1/2 | 1-1/2 |
| TDM 175 | 1-1/2 | 1-1/2 | 1-1/2 | 1-1/2 | 1-1/2 |
| TDM 200 | 1-1/2 | 1-1/2 | 1-1/2 | 1-1/2 | 1-1/2 |
| TDM 250 | 1-1/2 | 1-1/2 | 1-1/2 | 1-1/2 | 1-1/2 |
| TDM 275 | 2 | 1-1/2 | 1-1/2 | 1-1/2 | 1-1/2 |
| TDM 300 | 2 | 1-1/2 | 1-1/2 | 1-1/2 | 1-1/2 |
| TDM 350 | 2 | 1-1/2 | 1-1/2 | 1-1/2 | 1-1/2 |
| TDM 400 | 2 | 1-1/2 | 1-1/2 | 1-1/2 | 1-1/2 |
| TDM 500 | 2 | 1-1/2 | 1-1/2 | 1-1/2 | 1-1/2 |
| TDM 550 | 2 | 1-1/2 | 1-1/2 | 1-1/2 | 1-1/2 |
| TDM 600 | 2 | 2 | 2 | 1-1/2 | 1-1/2 |

DAT Series Air Turnover Systems

Specification

DAT Specification

SYSTEM:

PREPARED FOR:

JOB NAME:

DATE:

SCOPE

The Air Turnover unit shall be Model DAT _____ and supplied by Temprite Industries.

The unit shall be factory fabricated, assembled, wired and tested prior to shipment in accordance with the specification and equipment schedule.

The unit will include all components herein and as shown on the drawings. Alternate equipment, equal in design, construction, performance and capacity to unit(s) specified, must be shown with price deduct/add, if any. Approval of alternate equipment will be subject to review of shop drawings.

The unit shall be ETL /CGA approved and capable of following performance:

| | | |
|-------------------------------|------------------|-------------|
| Airflow Rate: | _____ | Scfm (Acfm) |
| Base Dimensions, L x W | _____ | Inches |
| Minimum Height, H | _____ | Inches |
| Main Fan Motor Size: | Qty. ____ - ____ | Hp |
| Induced Draft Fan Motor Size: | _____ | Hp |
| Heat Output: | _____ | Btuh |
| Heat Input: | _____ | Btuh |

CASING

The unit casing shall be constructed from 16 gauge galvanized steel formed into 2" deep 'C' panels with a maximum width of 24". Panels shall be fastened with zinc plated 1/4" bolts and nuts on 6" centers (sheetmetal screws and pop rivets are not acceptable) and be removable for servicing. Each section will have a 10 gauge formed structural base bolted together with 3/8" bolts and nuts.

Units with structural steel frames must be cleaned, primed and finished with two coats of enamel paint on all mild steel surfaces prior to assembly of the casing. Panels must be removable and cannot be welded to the structural frame.

When split for shipment, the unit splits will be framed with 10 gauge formed channel with drilled notch holes at 6" centers. Zinc plated 3/8" bolts and nuts will be supplied for field assembly.

The entire unit shall be brushed or scraped to remove any dirt, dust or other foreign substances. The unit will be primed with a vinyl wash and finish coated with a heat resistant alkyd enamel.

Hinged access doors with zinc plated piano type hinges shall be supplied to allow physical entry to all sections requiring inspection and periodic maintenance. Access doors shall be complete with handles.

PROPELLER FAN SECTION

Propeller fans shall be AMCA rated for both air and sound performance. Each fan shall have a minimum of five fabricated steel blades. Propellers shall be securely attached to fan shafts, and statically and dynamically balanced at the factory.

Ground and polished steel fan shafts shall be mounted in permanently lubricated, sealed ball bearing pillow blocks. Bearings shall be selected for a minimum (L10) life in excess of 100,000 hours at maximum cataloged operating speeds. Drives shall be sized for a minimum of 150% of driven horsepower. Pulleys shall be of the fully machined cast iron type, keyed and securely attached to wheel and motor shafts. Motor sheaves shall be adjustable for system balancing.

Drive frame and panel assemblies shall be galvanized steel or painted steel. Drive frames shall be formed channels and fan panels shall have pre-punched mounting holes, formed flanges, and a deep formed inlet venturi.

FORWARD CURVED FAN SECTION

The fan section shall be upstream of the heat exchanger to ensure constant air volume at the specified discharge temperature. The fan(s) shall be centrifugal AMCA rated forward curved statically and dynamically balanced. The fan(s) shall be double width, double inlet with motor and drives in the air stream.

The fan is to be mounted on a heavy duty, turned and ground solid steel shaft designed with its maximum operating speed not exceeding 75% of its first critical speed. The bearings are to be of the pre-lubricated, self aligning type. Drives have a capacity 25% greater than the motor horsepower and have a minimum of two belts. Up to 7.5 HP, the motor sheaves shall be of the adjustable pitch type.

DAT Series Air Turnover Systems

MOTORS

Motors shall be rated for fan duty, {ODP} {TEFC}, T-frame and _____ volt, _____ cycle, _____ phase. The fan motor shall be mounted on an adjustable base and wired in flexible conduit to the control panel.

The fan wheel, shaft, drives, and motor assembly shall be electrically balanced as a complete assembly in the factory.

INDIRECT GAS FIRED SECTION

The heat exchanger shall be rated at a minimum 80% efficiency at rated output. The flue gas travel shall be of four-pass design, with no internal baffles. The primary heat transfer surface and header shall be of 409 stainless steel; the secondary heat transfer surface shall be steel boiler tube (Option – 409 stainless steel). The heat exchanger design shall permit unrestricted lateral and peripheral expansion during the heating and cooling cycle. The surface temperature of the heat exchanger shall not exceed 75% of its scaling temperature when operating at rated capacity. A pressure relief door complete with an observation window to view the complete flame and pilot shall be provided.

An integrally mounted, heavy duty, radial blade induced draft fan c/w motor shall be provided. The induced draft fan shall be equipped with a manual damper complete with locking quadrant to ensure proper draft, rated efficiency and extended heat exchanger performance.

GAS BURNER

The burner shall fire natural gas (Option – propane) and be arranged for high/low operation (Option – full modulation with low fire start and a 4 to 1 turndown ratio). The factory wired and piped valve train shall be mounted on the unit and be complete with:

- an (low pressure) appliance regulator
 - automatic main gas shut-off valve
 - main manual test firing shut-off valve
 - pilot manual shut-off valve
 - pilot pressure regulator
 - pilot automatic shut-off valve
 - pilot manual test firing shut-off valve
-

LIGHT OIL BURNER

The burner shall be No. 2 fuel oil with a maximum viscosity of 40 SSU at 100°F and be arranged for high/low operation (on/off firing below 5 GPH). The oil burner shall be of the high pressure atomizing type with integral combustion air blower and motor, air diffuser ring, two-stage fuel pump and combustion air damper. The removable drawer assembly shall contain oil nozzles and ignition electrodes. An electronic programming relay with the photocell shall be used for flame supervision. The factory piped and wired valve train shall be mounted on the unit and come complete with:

- oil filter
- shut-off valve
- oil shut-off and pressure reducing valve
- heat dissipating coil
- solenoid valve(s)

ELECTRICAL CONTROLS

An NEMA 1 control panel complete with hinged access door shall be mounted on the unit and wired. All control components are to be labeled and individually wired to a numbered terminal strip to aid in servicing. All wiring shall be color coded and number tagged at each end to match the control diagram supplied. Full operating and maintenance instructions shall accompany each unit. All wiring between the controls and valves shall be run in flexible conduit. The control system shall include but not be limited to the following components required for automatic operation:

- main disconnect switch
 - control circuit transformer
 - fan motor starters, overloads and subcircuit fuses
 - control circuit fuses
 - control relays
 - electronic flame relay complete with alarm contacts
 - induced draft fan air proving differential switch
 - high limit switch
 - automatic/manual fan switch
 - heavy duty ignition transformer
-

FILTERS FOR FORWARD CURVED FAN UNITS

Air filters shall be 2" medium efficiency, pleated, disposable type. Filter media shall be of the non-woven cotton fabric and have an average efficiency of 25 - 30% on Ashrae Test Standard 52-76. Filters shall have a rated air velocity of 500 FPM and a final resistance of 0.9" w.g. Filters shall be rated Class 2 by Underwriter's Laboratories and each product shall bear the U.L. label indicating class and issue number. Face velocity shall not exceed those shown on the schedule.

FILTERS FOR PROPELLER FAN UNITS

Air filters shall be 1" washable media mounted in galvanized steel frames. Face velocity shall not exceed those shown on the schedule.

DAMPERS

The unit will be complete with a motorized damper(s) with a 16 gauge galvanized steel frame. Blades shall be rolled formed, triple V-groove 16 gauge galvanized steel, maximum 6" wide. Axles shall be 1/2" plated steel hex. Bearings shall be oilite bronze and linkage outside of the air stream. Blade edge seals shall be extruded dual vinyl. The damper and damper motor shall be mounted on the unit casing.

START UP

Start up to be performed by a factory trained technician and to include testing the controls and ensuring the proper operation of all the unit functions. Any wiring or piping connections required due to the unit being split in sections (including remote panels) is the responsibility of the installing contractor. Start up will not include air balancing.

In the interest of product improvement
we reserve the right to make changes without notice.



Sales & Service

1300 Midway Blvd. ■ Mississauga, Ontario L5T 2 G8
Phone: (905) 670-2219 ■ FAX: (905) 670-8377

Manufacturing

4830 Transport Drive ■ Dallas, Texas 75247
Phone (214) 638-6010 ■ FAX (214) 638-3324

<http://www.mestek.com>