

Contents

Typical Indoor Installations	0001
Indoor Unit Dimensions (Vertical)	0003
Indoor Unit Dimensions (Horizontal)	0005
Outdoor Unit Dimensions	0006
Indoor Filter and Mixing Box	0007
Outdoor Filter and Mixing Box	0008
Service Platform	0009
Discharge Nozzles	0010
Roof Curbs	0011
Stack	0012
Fan Charts	0013
Engineering Ratings Chart	0015
Specification	0016

TDM Series Indirect Fired Heaters

Typical Indoor Installations

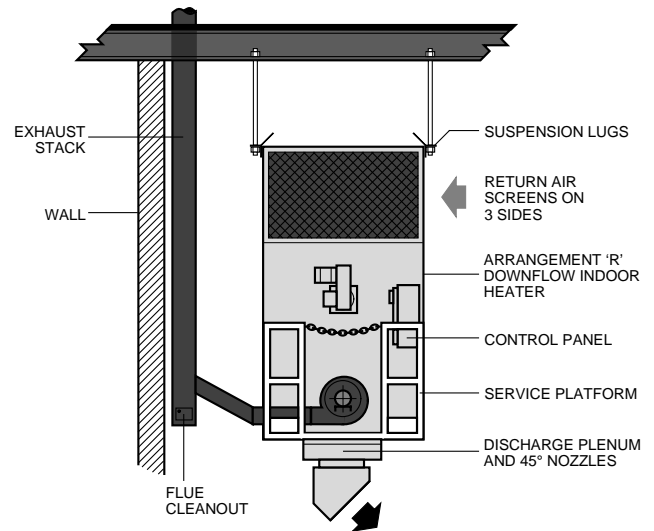
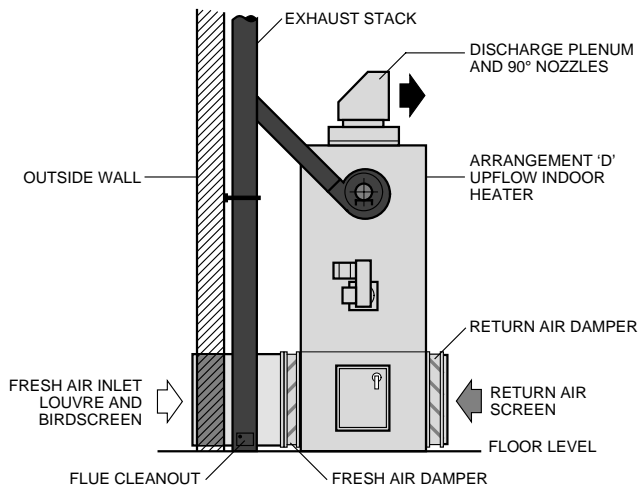

Indoor Floor Mounted Upflow Heater

This arrangement reduces installation costs by eliminating ductwork. The circulating airflow pattern reduces air stratification, thus conserving energy. Fresh Air and Return Air Dampers have been added to provide ventilation in building-occupied modes.

Indoor Suspended Downflow Heater

This arrangement is ideally suited for high bay buildings where floor space is at a premium. The high velocity Discharge Nozzles create a downflow air pattern, thereby bringing stratified air down to the working level. The Service Platform allows for easy maintenance.

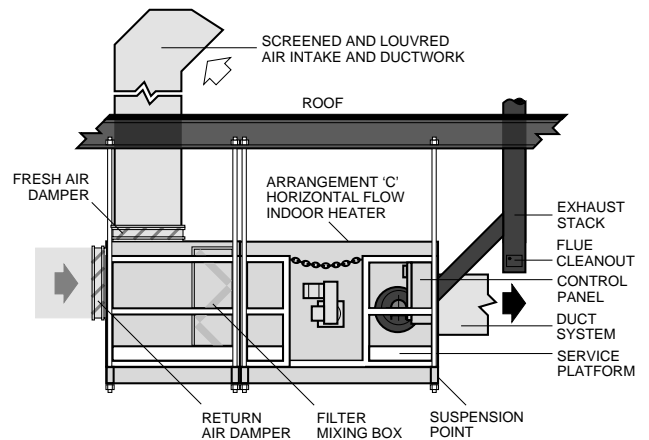
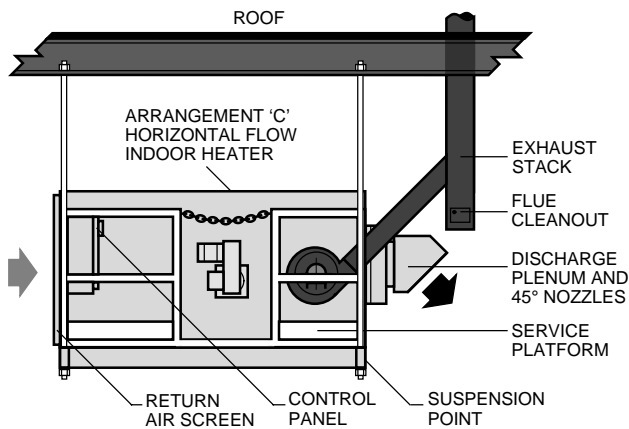

Indoor Suspended Horizontal Heater

This arrangement provides 100% recirculated air for space heating. It can be used to direct heated air at cold shipping and receiving door areas. Discharge Nozzles and a Service Platform are shown.

Indoor Suspended Horizontal Heating & Ventilation System

This arrangement can be used to heat and ventilate a building. Any combination of fresh air and return air can be delivered. The heater is equipped with a Filter Mixing Box, Service Platform and a High Efficiency Modulating Burner. Heated air is distributed through a duct system.

TDM Series Indirect Fired Heaters

Typical Outdoor Installations

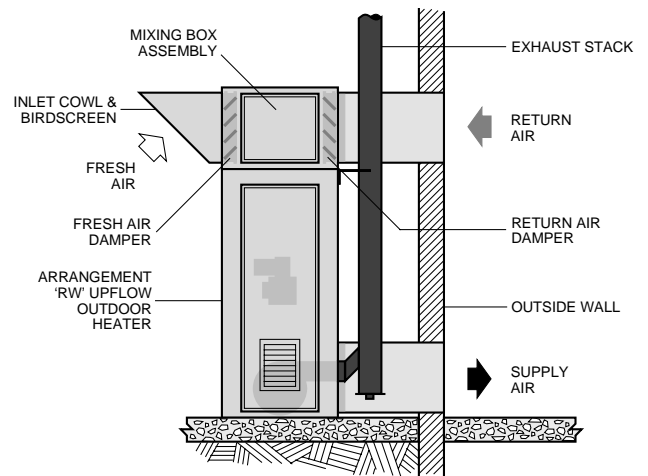
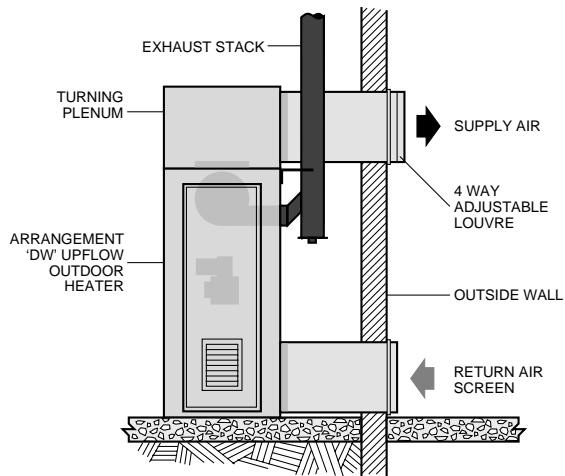

Outdoor Slab Mounted Upflow Heater

This arrangement is used for space heating where indoor space heaters would use up valuable floor space and be subject to damage. This packaged system is complete with Walk-in Enclosure, Turning Plenum and Return Air Screen.

Outdoor Slab Mounted Downflow Heater

This arrangement features an Inlet Cowl and Bird Screen, Mixing Box with Fresh Air and Return Air Dampers, Walk-in Service Enclosure and an efficient High Turndown Modulating Burner. This heating and ventilating system meets the requirements of many high bay mill type buildings.

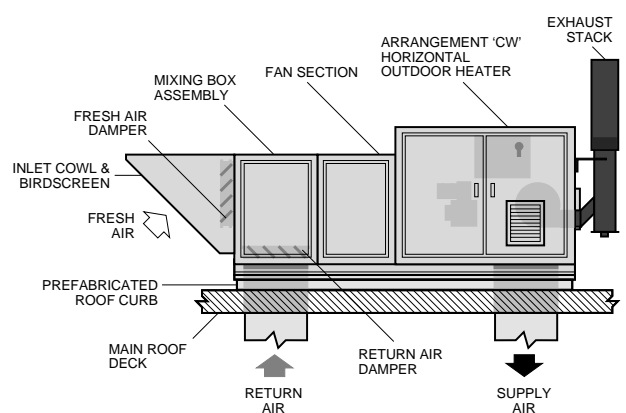
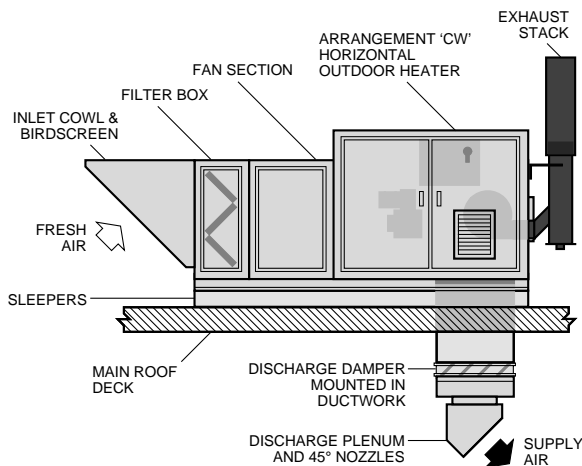

Outdoor Roof Mounted Downblast Air Make Up System

This arrangement includes an Inlet Cowl and Bird Screen, Filter Box, Service Enclosure, Exhaust Stack, Discharge Damper and Discharge Nozzles. This system will provide 100% make-up air to a variety of commercial and industrial buildings.

Outdoor Curb Mounted Downblast Heater

This arrangement includes an Inlet Cowl and Bird Screen, Mixing Box with Fresh Air and Return Air Dampers, Service Enclosure and an Exhaust Stack. This heating and ventilating system meets the requirements of most industrial and commercial buildings.

TDM Series Indirect Fired Heaters

Indoor Unit Dimensions – Arrangement D (Upflow)

Components:

1. MAIN DISCONNECT SWITCH
2. INDUCED DRAFT FAN
3. BURNER
4. MODELS 125-600 SPLIT FOR SHIPMENT
5. CONTROL PANEL
6. CLEANOUT PANEL
7. INSPECTION & RELIEF PORT
8. FAN & MOTOR ACCESS

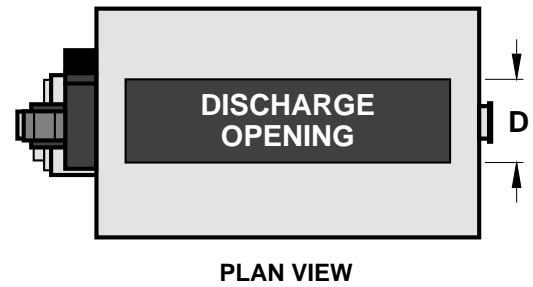

Notes:

1. ALL DIMENSIONS ARE IN INCHES AND SUBJECT TO MANUFACTURING TOLERANCES.
2. PROVIDE 42 INCH SERVICE CLEARANCE AT FRONT AND BACK OF UNIT

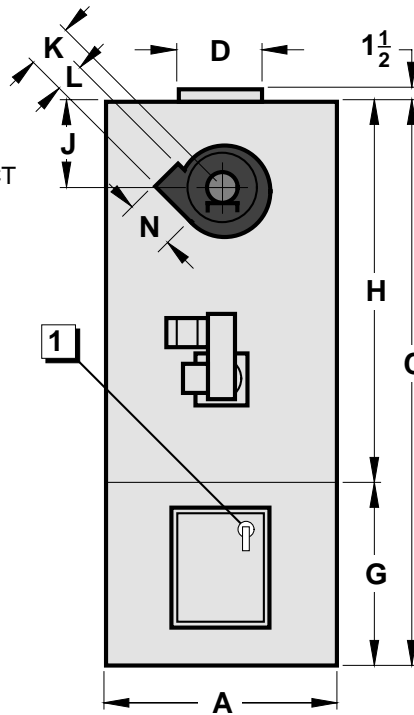

FRONT ELEVATION

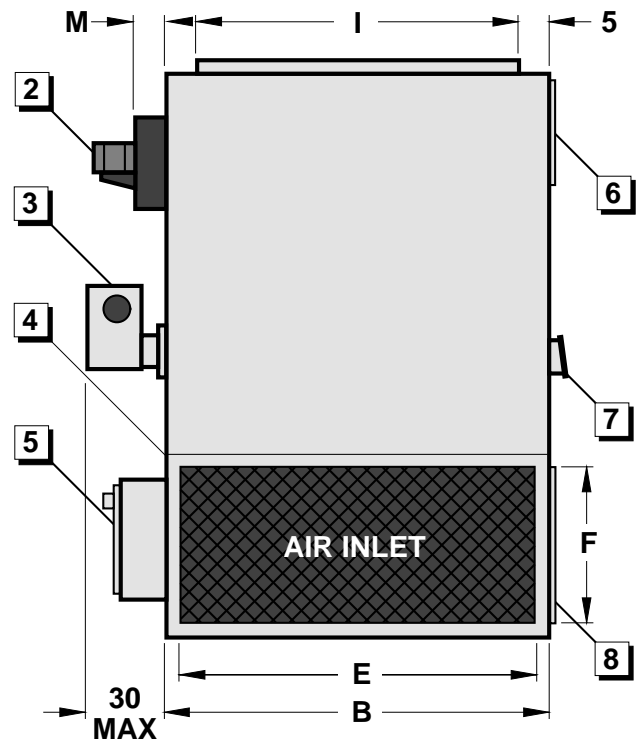

RIGHT SIDE ELEVATION

DIMENSIONS

TDM Model	Dimensions														Unit Weight (Lbs.)
	A	B	C	D	E	F	G	H	I	J	K*	L*	M*	N*	
25-35	38	48	98	18	44	34	38	60	38	14	9 $\frac{1}{2}$	6 $\frac{3}{8}$	6 $\frac{5}{8}$	9	1300
40-55	38	60	98	18	56	34	38	60	50	14	9 $\frac{1}{2}$	6 $\frac{3}{8}$	6 $\frac{5}{8}$	9	1500
65-75	38	80	98	18	76	34	38	60	70	14	9 $\frac{1}{2}$	6 $\frac{3}{8}$	6 $\frac{5}{8}$	9	1950
85-100	48	80	110	18	76	38	42	68	70	15 $\frac{1}{2}$	9 $\frac{1}{2}$	6 $\frac{3}{8}$	6 $\frac{5}{8}$	9	2500
125-175	54	100	121	24	96	38	42	79	90	21 $\frac{1}{2}$	13 $\frac{7}{8}$	9 $\frac{1}{8}$	9 $\frac{5}{8}$	13 $\frac{1}{2}$	3350
200-250	60	120	130	30	116	38	42	88	110	24 $\frac{1}{2}$	13 $\frac{7}{8}$	9 $\frac{1}{8}$	9 $\frac{5}{8}$	13 $\frac{1}{2}$	4200
275	65	140	137	30	136	41	45	92	130	18	13 $\frac{7}{8}$	9 $\frac{1}{8}$	9 $\frac{5}{8}$	13 $\frac{1}{2}$	5950
300-400	70	160	151	30	156	41	45	106	150	20	16 $\frac{1}{4}$	10 $\frac{3}{4}$	11 $\frac{3}{8}$	15 $\frac{1}{2}$	7600
500-600	80	180	219	48	176	74	78	141	170	14	19 $\frac{7}{16}$	12 $\frac{7}{16}$	11 $\frac{1}{8}$	15 $\frac{3}{8}$	13600

*Note: For Model 100 Oil Fired Unit K = 10 $\frac{7}{8}$, L = 7 $\frac{7}{8}$, M = 7 $\frac{5}{8}$, N = 10 $\frac{1}{2}$

Indoor Unit Dimensions – Arrangement R (Downflow)

Components:

1. MAIN DISCONNECT SWITCH
2. CONTROL PANEL
3. BURNER
4. INDUCED DRAFT FAN
5. FAN & MOTOR ACCESS
6. MODELS 125-600 SPLIT FOR SHIPMENT
7. INSPECTION & RELIEF PORT
8. CLEANOUT PANEL

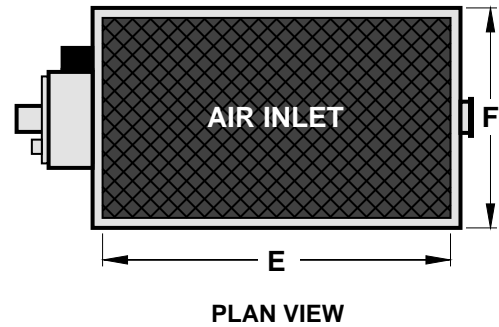

Notes:

1. ALL DIMENSIONS ARE IN INCHES AND SUBJECT TO MANUFACTURING TOLERANCES.
2. PROVIDE 42 INCH SERVICE CLEARANCE AT FRONT AND BACK OF UNIT

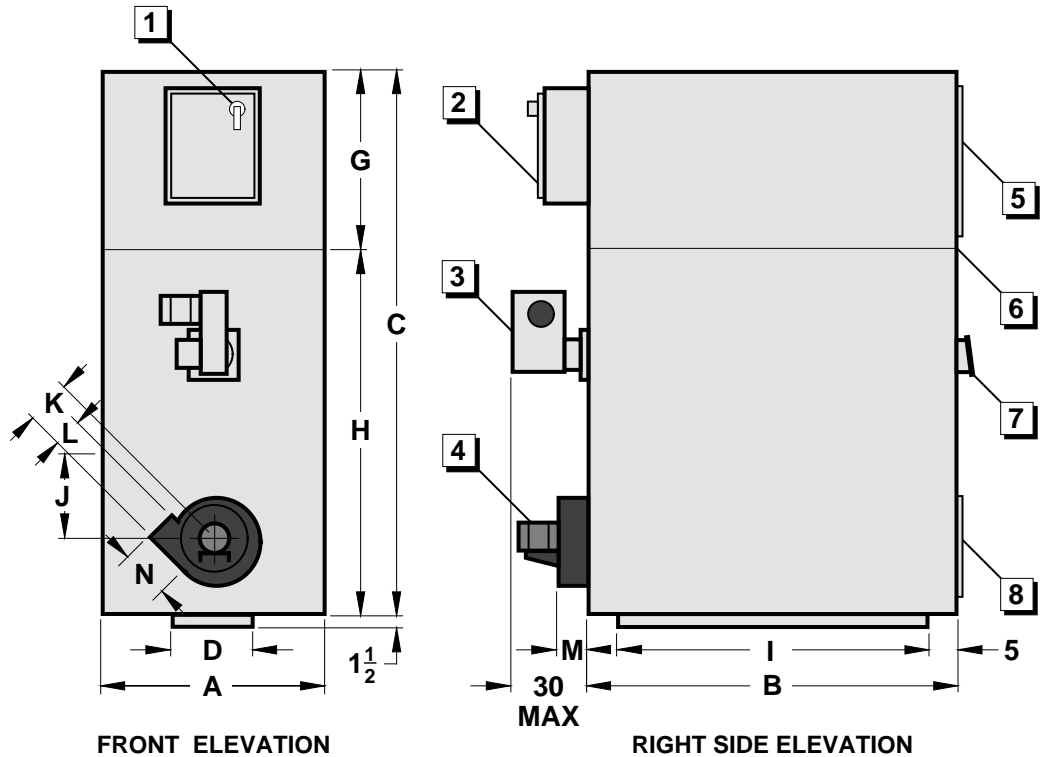

DIMENSIONS

TDM Model	Dimensions														Unit Weight (Lbs.)
	A	B	C	D	E	F	G	H	I	J	K*	L*	M*	N*	
25-35	38	48	98	18	44	34	38	60	38	14	9 $\frac{1}{2}$	6 $\frac{3}{8}$	6 $\frac{5}{8}$	9	1300
40-55	38	60	98	18	56	34	38	60	50	14	9 $\frac{1}{2}$	6 $\frac{3}{8}$	6 $\frac{5}{8}$	9	1500
65-75	38	80	98	18	76	34	38	60	70	14	9 $\frac{1}{2}$	6 $\frac{3}{8}$	6 $\frac{5}{8}$	9	1950
85-100	48	80	110	18	76	38	42	68	70	15 $\frac{1}{2}$	9 $\frac{1}{2}$	6 $\frac{3}{8}$	6 $\frac{5}{8}$	9	2500
125-175	54	100	121	24	96	38	42	79	90	21 $\frac{1}{2}$	13 $\frac{7}{8}$	9 $\frac{1}{8}$	9 $\frac{5}{8}$	13 $\frac{1}{2}$	3350
200-250	60	120	130	30	116	38	42	88	110	24 $\frac{1}{2}$	13 $\frac{7}{8}$	9 $\frac{1}{8}$	9 $\frac{5}{8}$	13 $\frac{1}{2}$	4200
275	65	140	137	30	136	41	45	92	130	18	13 $\frac{7}{8}$	9 $\frac{1}{8}$	9 $\frac{5}{8}$	13 $\frac{1}{2}$	5950
300-400	70	160	151	30	156	41	45	106	150	20	16 $\frac{1}{4}$	10 $\frac{3}{4}$	11 $\frac{3}{8}$	15 $\frac{1}{2}$	7600
500-600	80	180	219	48	176	74	78	141	170	14	19 $\frac{7}{16}$	12 $\frac{7}{16}$	11 $\frac{1}{8}$	15 $\frac{3}{8}$	13600

*Note: For Model 100 Oil Fired Unit K = 10 $\frac{7}{8}$, L = 7 $\frac{7}{8}$, M = 7 $\frac{5}{8}$, N = 10 $\frac{1}{2}$

Indoor Unit Dimensions – Arrangement C (Horizontal Flow)

Components:

1. FAN & MOTOR ACCESS
2. MODELS 125-600 SPLIT FOR SHIPMENT
3. INSPECTION & RELIEF PORT
4. CLEANOUT PANEL
5. CONTROL PANEL
6. BURNER
7. INDUCED DRAFT FAN
8. MAIN DISCONNECT SWITCH
9. OPTIONAL DOWN BLAST DISCHARGE (PLENUM EXTENSION REQ'D ON TDM 500-600)

Notes:

1. ALL DIMENSIONS ARE IN INCHES AND SUBJECT TO MANUFACTURING TOLERANCES.
2. PROVIDE 42 INCH SERVICE CLEARANCE AT FRONT AND BACK OF UNIT.

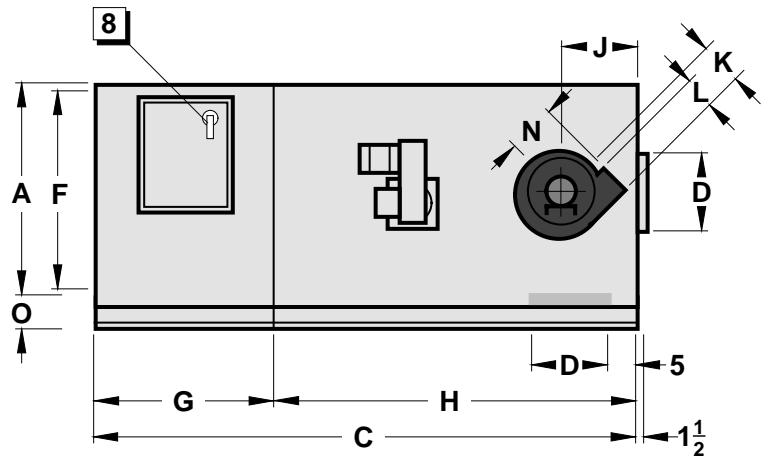
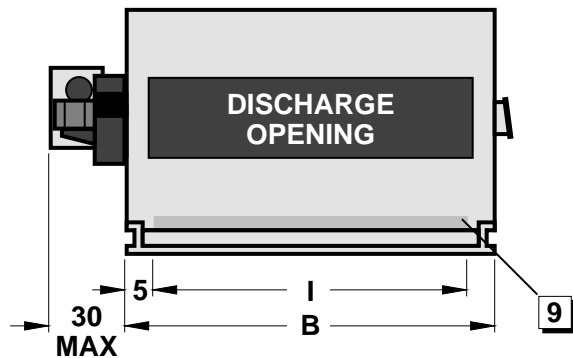
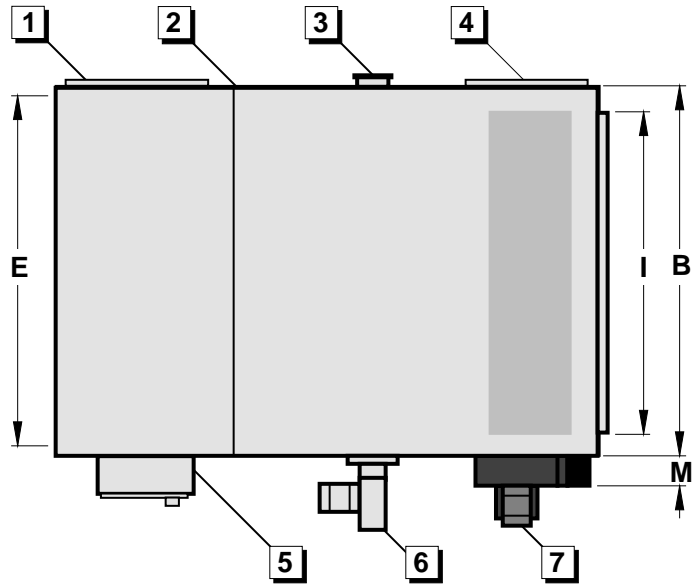

DIMENSIONS

TDM Model	Dimensions															Unit Weight (Lbs.)
	A	B	C	D	E	F	G	H	I	J	K*	L*	M*	N*	O	
25-35	38	48	98	18	44	34	38	60	38	14	9 $\frac{1}{2}$	6 $\frac{3}{8}$	6 $\frac{5}{8}$	9	4	1300
40-55	38	60	98	18	56	34	38	60	50	14	9 $\frac{1}{2}$	6 $\frac{3}{8}$	6 $\frac{5}{8}$	9	4	1500
65-75	38	80	98	18	76	34	38	60	70	14	9 $\frac{1}{2}$	6 $\frac{3}{8}$	6 $\frac{5}{8}$	9	4	1950
85-100	48	80	110	18	76	44	42	68	70	15 $\frac{1}{2}$	9 $\frac{1}{2}$	6 $\frac{3}{8}$	6 $\frac{5}{8}$	9	4	2500
125-175	54	100	121	24	96	50	42	79	90	21 $\frac{1}{2}$	13 $\frac{7}{8}$	9 $\frac{1}{8}$	9 $\frac{5}{8}$	13 $\frac{1}{2}$	6	3350
200-250	60	120	130	30	116	56	42	88	110	24 $\frac{1}{2}$	13 $\frac{7}{8}$	9 $\frac{1}{8}$	9 $\frac{5}{8}$	13 $\frac{1}{2}$	6	4200
275	65	140	137	30	136	61	45	92	130	18	13 $\frac{7}{8}$	9 $\frac{1}{8}$	9 $\frac{5}{8}$	13 $\frac{1}{2}$	6	5950
300-400	70	160	151	30	156	66	45	106	150	20	16 $\frac{1}{4}$	10 $\frac{3}{4}$	11 $\frac{3}{8}$	15 $\frac{1}{2}$	8	7600
500-600	80	180	219	48	176	76	78	141	170	14	19 $\frac{7}{16}$	12 $\frac{7}{16}$	11 $\frac{1}{8}$	15 $\frac{3}{8}$	8	13600

*Note: For Model 100 Oil Fired Unit K = 10 $\frac{7}{8}$, L = 7 $\frac{7}{8}$, M = 7 $\frac{5}{8}$, N = 10 $\frac{1}{2}$

Outdoor Unit Dimensions – Arrangement CW (Horizontal Flow)

Components:

1. MODELS 125-600 SPLIT FOR SHIPMENT
2. INSPECTION & RELIEF PORT
3. CLEANOUT PANEL
4. FAN & MOTOR ACCESS
5. BURNER
6. CONTROL PANEL
7. INDUCED DRAFT FAN
8. OPTIONAL DOWN BLAST DISCHARGE
(PLENUM EXTENSION REQ'D ON TDM 500-600)

Notes:

1. ALL DIMENSIONS ARE IN INCHES AND SUBJECT TO MANUFACTURING TOLERANCES.

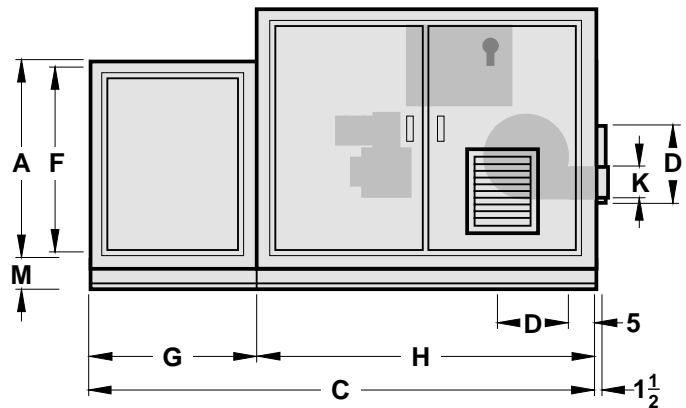
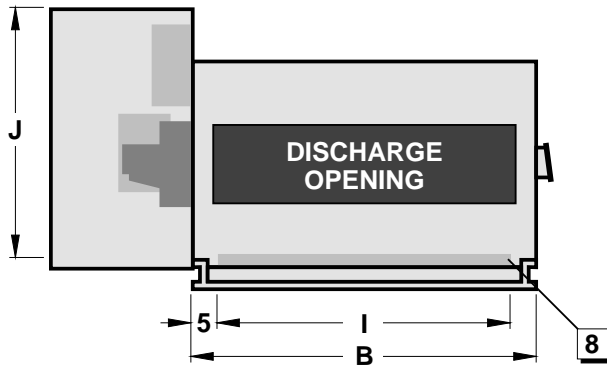
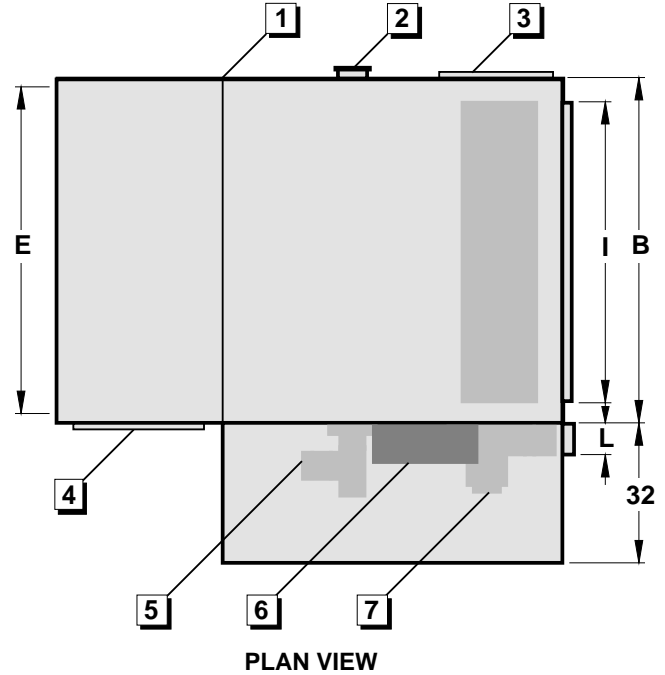

DIMENSIONS

TDM Model	Dimensions													Unit Weight (Lbs.)
	A	B	C	D	E	F	G	H	I	J	K*	L*	M	
25-35	38	48	98	18	44	34	38	60	38	54	6 ³ / ₈	6 ⁵ / ₈	4	1600
40-55	38	60	98	18	56	34	38	60	50	54	6 ³ / ₈	6 ⁵ / ₈	4	1800
65-75	38	80	98	18	76	34	38	60	70	54	6 ³ / ₈	6 ⁵ / ₈	4	2250
85-100	48	80	110	18	76	44	42	68	70	58	6 ³ / ₈	6 ⁵ / ₈	4	2800
125-175	54	100	121	24	96	50	42	79	90	66	9 ¹ / ₈	9 ⁵ / ₈	6	3750
200-250	60	120	130	30	116	56	42	88	110	70	9 ¹ / ₈	9 ⁵ / ₈	6	4650
275	65	140	137	30	136	61	45	92	130	75	9 ¹ / ₈	9 ⁵ / ₈	6	6400
300-400	70	160	151	30	156	66	45	106	150	80	10 ³ / ₄	11 ³ / ₈	8	8150
500-600	80	180	219	48	176	76	78	141	170	80	12 ⁷ / ₁₆	11 ¹ / ₈	8	15500

*Note: For Model 100 Oil Fired Unit K = 7¹/₈, L = 7⁵/₈

TDM Series Indirect Fired Heaters

Indoor Filter and Mixing Box Dimensions

Components:

1. DAMPER MOTOR(S)
2. PARALLEL BLADE FRESH AIR DAMPER
3. JACKSHAFT ASSEMBLY
(SUPPLIED ON DAMPERS OVER 48" WIDE)
4. PARALLEL BLADE RETURN AIR DAMPER
5. FILTER ACCESS (CAN BE AT EITHER END)

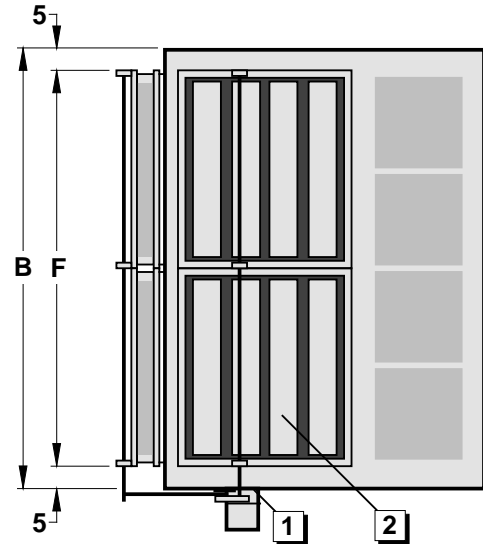

PLAN VIEW

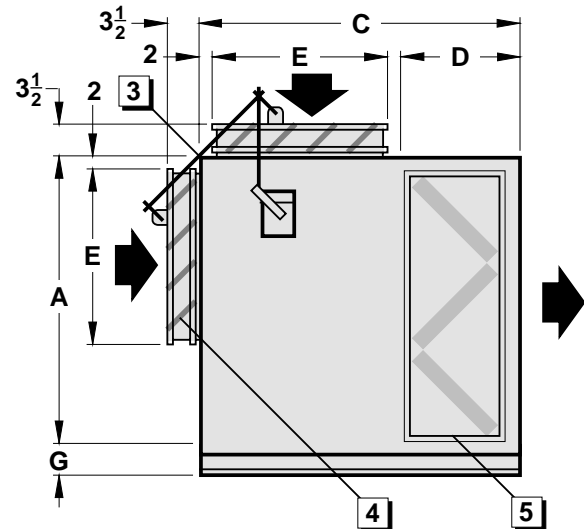

FRONT ELEVATION

Notes:

1. ALL DIMENSIONS ARE IN INCHES AND SUBJECT TO MANUFACTURING TOLERANCES.
2. FILTERS SUPPLIED ARE 2" THICK REPLACEABLE FIBERGLASS MEDIA WITH PERMANENT GALVANIZED HOLDING FRAMES. FILTER CAPACITY IS BASED ON NOMINAL RATED VELOCITY OF 500 F.P.M. OPTIONAL FILTERS AVAILABLE.
3. DAMPERS SUPPLIED HAVE 16 GAUGE GALVANIZED STEEL BLADES WITH CYCOLOY BEARINGS.
4. ON HORIZONTAL UNITS THE FILTER BOX OR FILTER MIXING BOX IS ATTACHED TO THE COMMON CHANNEL BASE. ON UPFLOW OR DOWNFLOW ARRANGEMENTS THE FILTER BOX OR MIXING BOX DO NOT INCLUDE CHANNEL BASES.

DIMENSIONS

TDM Model	Capacity CFM	Dimensions							No. & Size of Filters	Filter Box Weight (Lbs.)	Filter/Mix Box Weight (Lbs.)
		A	B	C*	D**	E	F	G			
25-35	5600	38	48	48	23	18	38	4	4-20X20X2	120	410
40-55	8400	38	60	48	23	18	50	4	6-20X20X2	135	475
65-75	11200	38	80	48	23	18	70	4	8-20X20X2	175	610
85-100	16800	48	80	48	23	18	70	4	12-20X20X2	225	705
125-175	21000	54	100	54	23	24	90	6	15-20X20X2	310	875
200-250	33600	60	120	62	25	30	110	6	24-20X20X2	385	1160
275	39200	65	140	62	25	30	130	6	28-20X20X2	405	1435
300-400	44800	70	160	60	23	30	150	8	32-20X20X2	570	1645
500-600	56500	80	180	66	23	36	170	8	45-20X20X2	900	2500

Note: * Dimensions for Filter and Mixing Box **Dimensions for Filter Box Only

TDM Series Indirect Fired Heaters

Outdoor Filter and Mixing Box Dimensions

Components:

1. INLET COWL & BIRDSCREEN
2. PARALLEL BLADE FRESH AIR DAMPER
3. PARALLEL BLADE RETURN AIR DAMPER
4. DAMPER MOTOR(S)
5. JACKSHAFT ASSEMBLY
(SUPPLIED ON DAMPERS OVER 48" WIDE)
6. DAMPER ACCESS (CAN BE AT EITHER END)
7. FILTER ACCESS (CAN BE AT EITHER END)

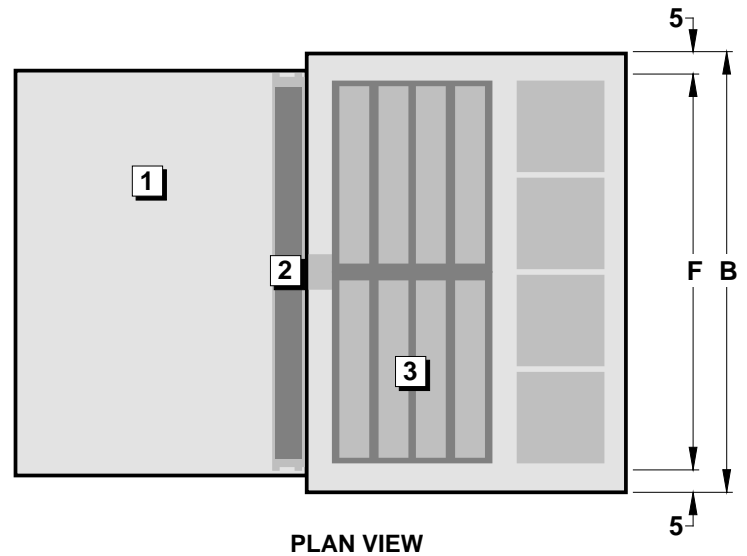

PLAN VIEW

Notes:

1. ALL DIMENSIONS ARE IN INCHES AND SUBJECT TO MANUFACTURING TOLERANCES.
2. FILTERS SUPPLIED ARE 2" THICK REPLACEABLE FIBERGLASS MEDIA WITH PERMANENT GALVANIZED HOLDING FRAMES. FILTER CAPACITY IS BASED ON NOMINAL RATED VELOCITY OF 500 F.P.M. OPTIONAL FILTERS AVAILABLE.
3. DAMPERS SUPPLIED HAVE 16 GAUGE GALVANIZED STEEL BLADES
4. THE INLET COWL AND BIRDSREEN IS FITTED IN THE FACTORY. ON MODELS 275-600 THE INLET COWL AND BIRDSREEN IS SHIPPED SEPARATELY WITH NECESSARY HARDWARE FOR FIELD INSTALLATION.

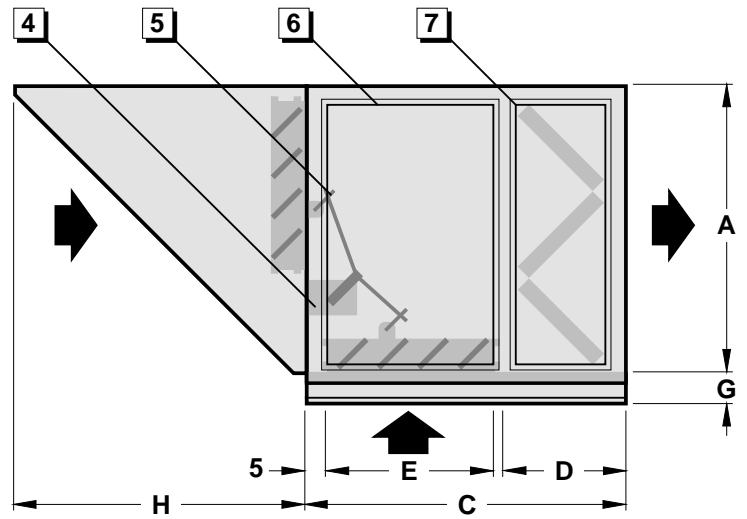

FRONT ELEVATION

DIMENSIONS

TDM Model	Capacity CFM	Dimensions								No. & Size of Filters	Filter Box Weight (Lbs.)	Filter/Mix Box Weight (Lbs.)	Inlet Cowl Weight (Lbs.)
		A	B	C*	D**	E	F	G	H				
25-35	5600	38	48	48	23	18	38	4	42	4-20X20X2	120	410	100
40-55	8400	38	60	48	23	18	50	4	42	6-20X20X2	135	475	110
65-75	11200	38	80	48	23	18	70	4	42	8-20X20X2	175	610	135
85-100	16800	48	80	48	23	18	70	4	52	12-20X20X2	225	705	275
125-175	21000	54	100	54	23	24	90	6	55	15-20X20X2	310	875	400
200-250	33600	60	120	62	25	30	110	6	61	24-20X20X2	385	1160	510
275	39200	65	140	62	25	30	130	6	66	28-20X20X2	405	1435	600
300-400	44800	70	160	60	23	30	150	8	71	32-20X20X2	570	1645	690
500-600	56500	80	180	66	34	36	170	8	81	45-20X20X2	900	2500	1100

Note: * Dimensions for Filter and Mixing Box **Dimensions for Filter Box Only

Service Platforms

Service Platform — Arrangement C (Horizontal Flow)

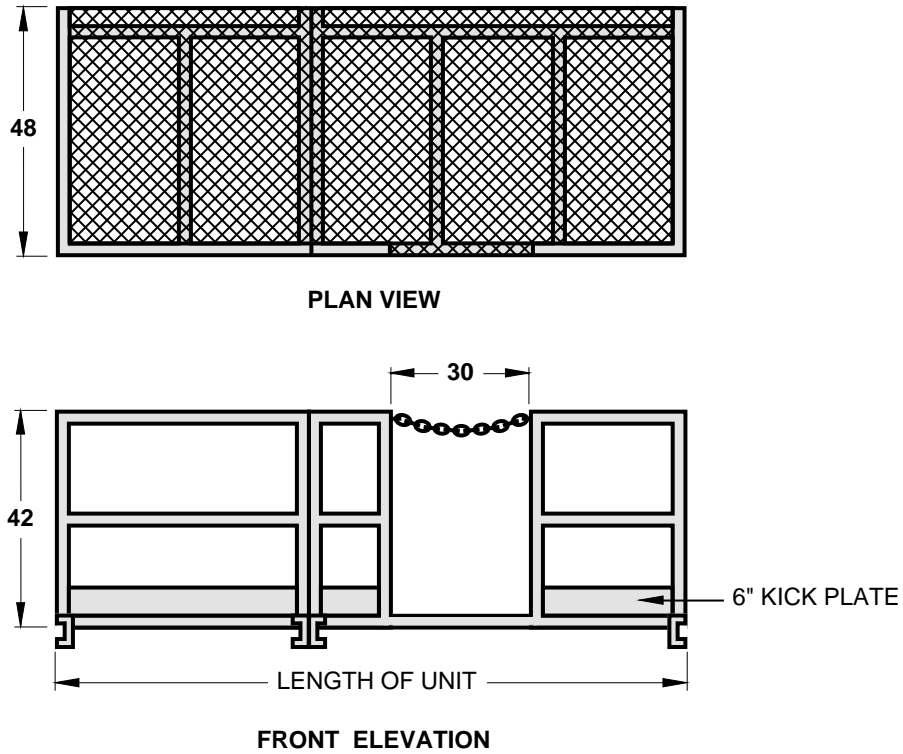

Service Platform — Arrangement R (Downflow)

Note:

- 1. OPTIONAL CHANNEL SUPPORTED PLATFORM AVAILABLE

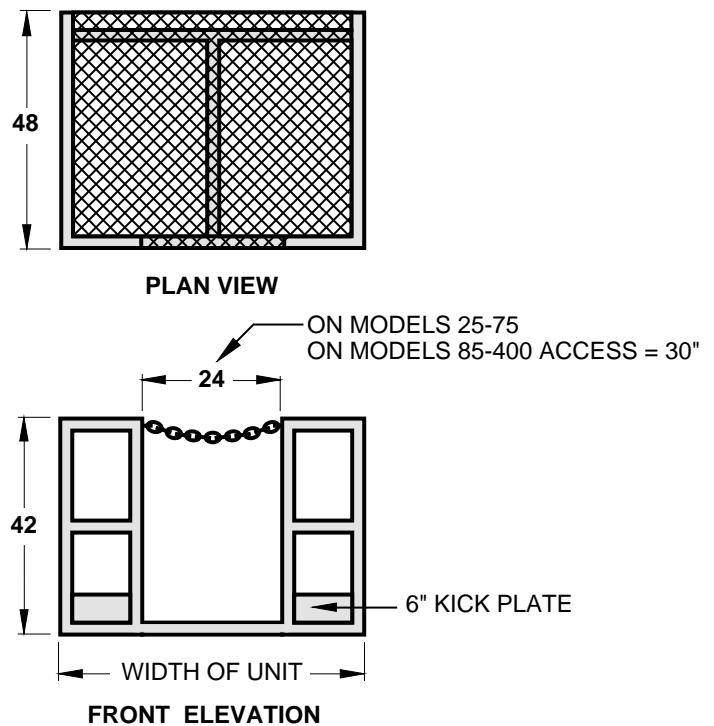

TDM Series Indirect Fired Heaters

Discharge Plenum & Nozzle Dimensions

90° DISCHARGE NOZZLES

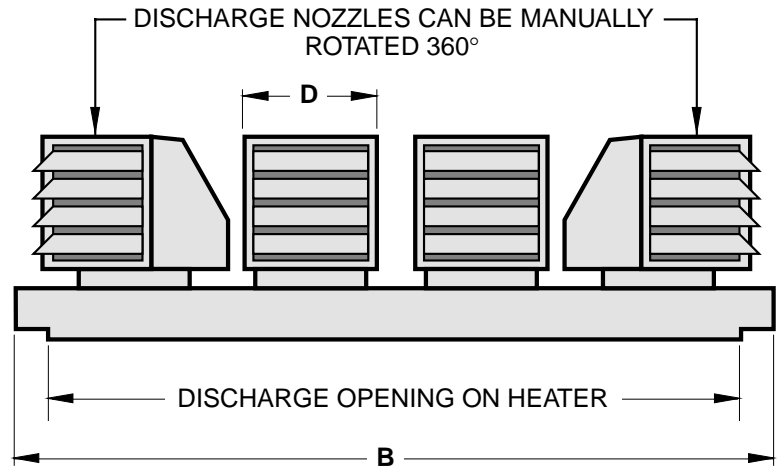
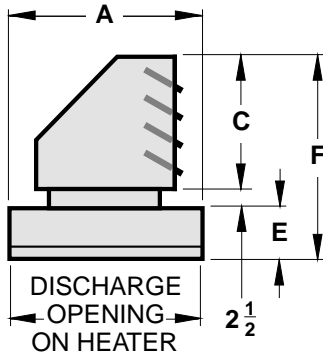

45° DISCHARGE NOZZLES

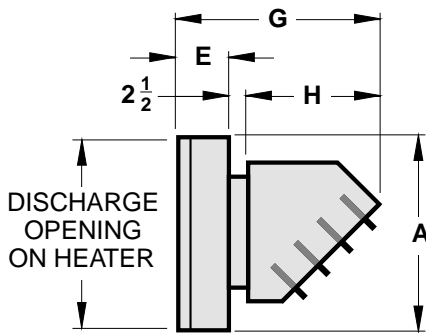

Notes:

1. ALL DIMENSIONS ARE IN INCHES AND SUBJECT TO MANUFACTURING TOLERANCES.
2. DIFFUSING VANES ARE ADJUSTABLE.
3. DISCHARGE PLENUM AND NOZZLES ARE SHIPPED LOOSE FOR FIELD INSTALLATION BY OTHERS.
4. CUSTOM DESIGNS AVAILABLE.

DIMENSIONS

TDM Model	Dimensions								No. of Nozzles	Weight (Lbs.)
	A	B	C	D	E	F	G	H		
25-35	18	48	15	15	6 1/2	24	22 1/2	13 1/2	2	60
40-55	18	60	15	15	6 1/2	24	22 1/2	13 1/2	3	85
65-75	18	80	15	15	6 1/2	24	22 1/2	13 1/2	4	135
85-100	18	80	15	15	6 1/2	24	22 1/2	13 1/2	4	135
125-175	24	100	18	18	6 1/2	27	24 1/2	15 1/2	5	205
200-250	30	120	18	18	6 1/2	27	24 1/2	15 1/2	5	265
275	30	140	18	18	6 1/2	27	24 1/2	15 1/2	6	310
300-400	30	160	18	18	6 1/2	27	24 1/2	15 1/2	7	360
500-600										

Perimeter Roof Curb

Typical Plan View

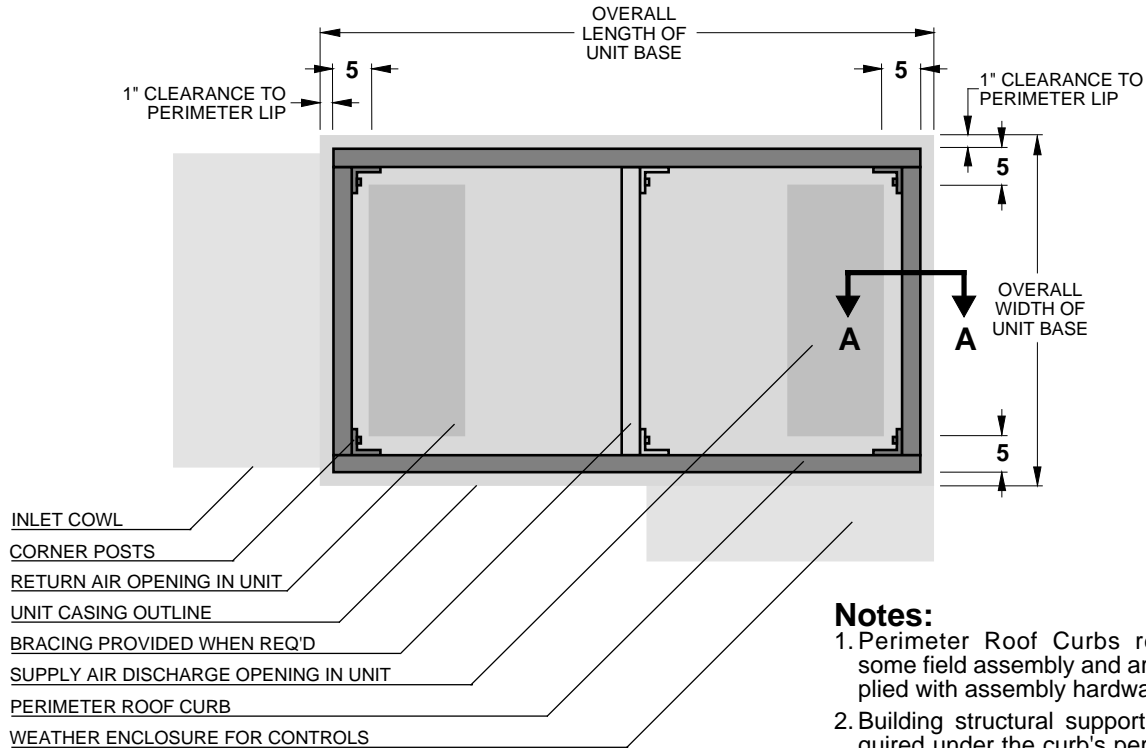

Notes:

1. Perimeter Roof Curbs require some field assembly and are supplied with assembly hardware.
2. Building structural support is required under the curb's perimeter and, on split units, under the centre brace as well.

Typical Mounting Details

This is a suggested method of supporting and installing an outdoor unit on a factory fabricated perimeter type curb. All local regulation codes are to be conformed to and are the responsibility of the installer. The curb is fabricated from heavy gauge satincoat galvanized steel with a factory installed wood nailing strip. Sleeves are provided on the supply air opening(s) of the unit for the attachment of ducting. Consult notes on certified drawings for further installation instructions.

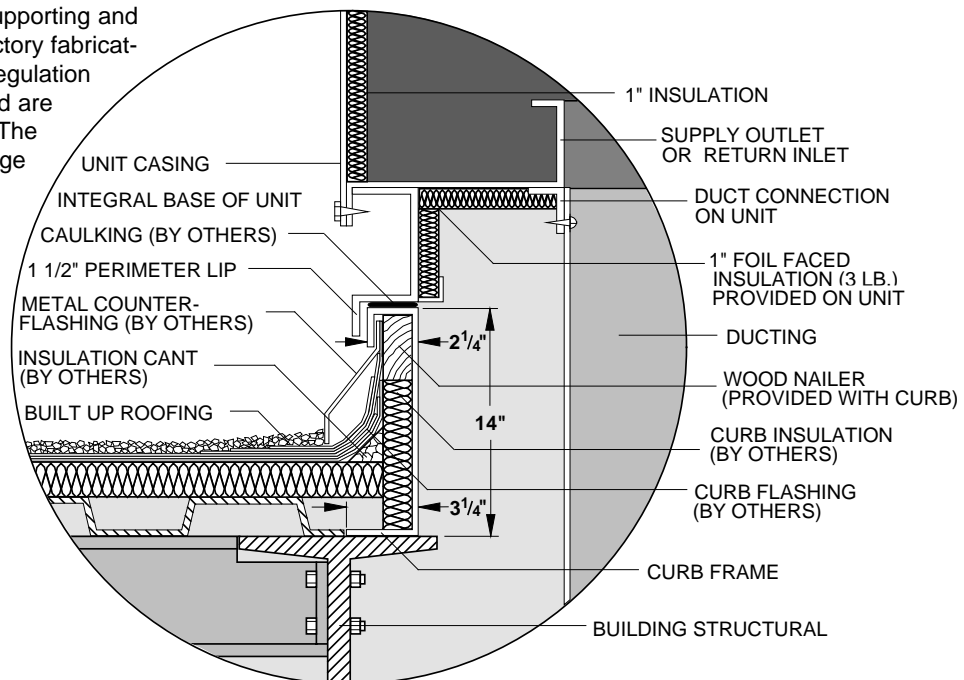

Section "A-A"

TDM Series Indirect Fired Heaters

Typical Type 'C' Stack Installation

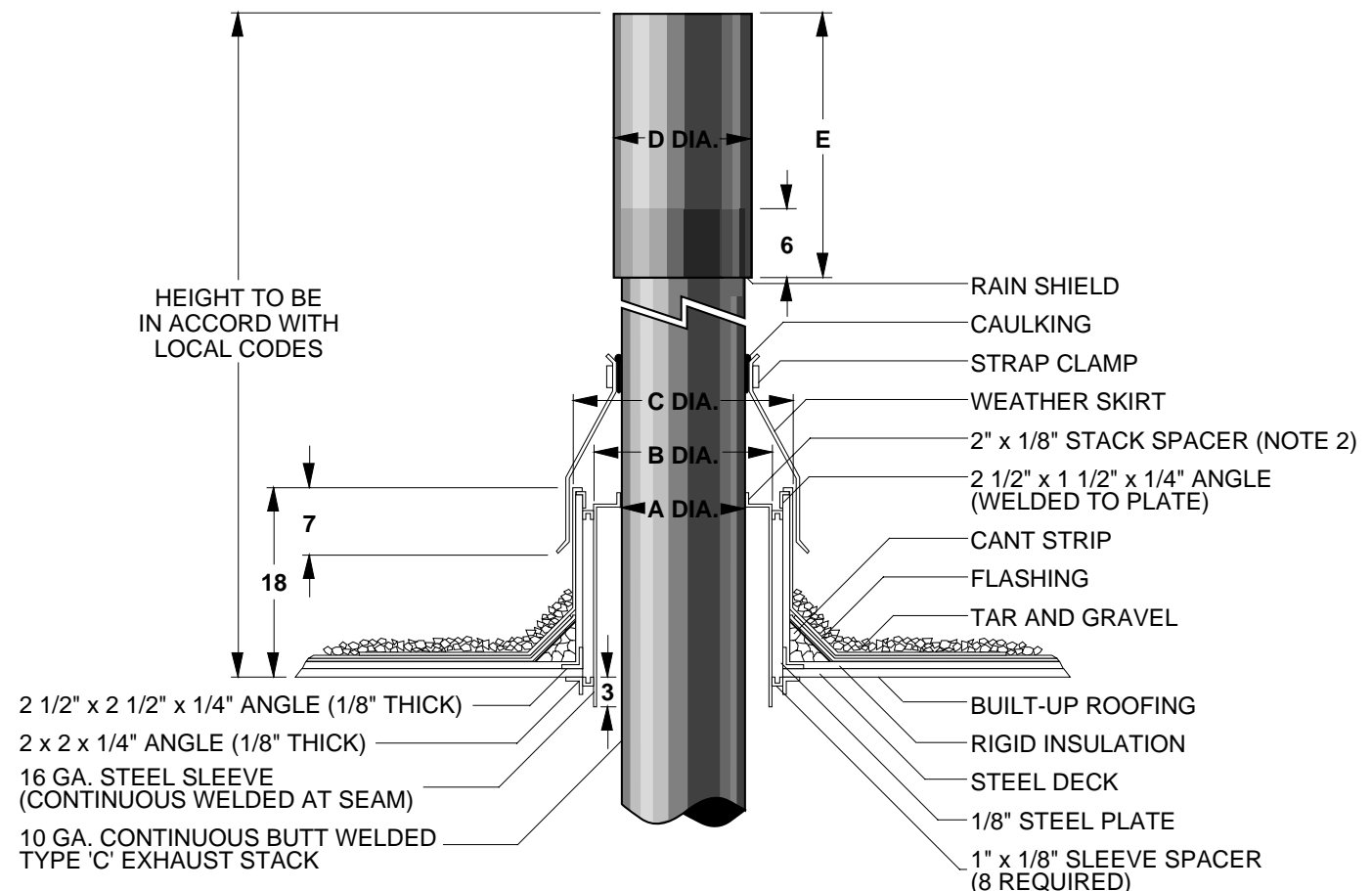

DIMENSIONS

TDM Model	Dimensions in Inches				
	A	B	C	D	E
25-55	8	12	14	9	48
65-100	10	14	16	11	48
125-250	12	16	18	13	48
275-400	14	18	20	15	56
500-600	16	20	22	17	64

Notes:

1. WEIGHT OF STACK MUST BE SUPPORTED FROM FLOOR OR BUILDING STRUCTURE. DO NOT SUPPORT STACK FROM INDUCED DRAFT FAN ON UNIT.
2. FOUR (4) STACK SPACERS ARE REQUIRED—WELDED TO SLEEVE, BUT NOT TO THE STACK—TO ALLOW FOR CREEP DURING EXPANSION AND CONTRACTION.

Fan Chart 1

TDM MODEL	VOLUME FLOW CFM	TOTAL EXTERNAL STATIC PRESSURE IN INCHES OF WATER COLUMN											
		0.25		0.5		0.75		1.0		1.25		1.5	
		RPM	BHP	RPM	BHP	RPM	BHP	RPM	BHP	RPM	BHP	RPM	BHP
25	2315	575	0.5	700	0.6	798	0.8	890	0.9	980	1.1	1060	1.2
	2437	580	0.5	700	0.6	800	0.8	895	0.9	980	1.2	1060	1.3
	2572	605	0.6	715	0.7	810	0.9	905	1.0	985	1.2	1065	1.3
	2723	620	0.6	727	0.8	822	0.9	914	1.1	989	1.3	1070	1.4
	2894	640	0.7	742	0.8	841	1.0	923	1.2	1000	1.3	1081	1.5
35	3241	635	0.6	744	0.8	835	1.0	930	1.2	1020	1.4	1100	1.6
	3411	658	0.6	770	0.8	850	1.0	950	1.3	1035	1.5	1115	1.7
	3600	690	0.8	795	1.0	880	1.1	970	1.4	1055	1.6	1133	1.9
	3813	736	0.9	825	1.1	909	1.3	1000	1.6	1073	1.8	1150	2.0
	4051	755	1.0	850	1.3	927	1.5	1017	1.7	1087	2.0	1162	2.2
40	3704	630	0.7	750	0.9	850	1.2	950	1.4	1050	1.7	1140	1.9
	3899	650	0.8	765	1.0	860	1.3	967	1.5	1060	1.8	1150	2.0
	4115	690	0.9	795	1.2	880	1.4	988	1.6	1075	1.9	1150	2.2
	4357	710	1.0	810	1.2	900	1.5	1000	1.7	1083	2.0	1163	2.4
	4630	735	1.2	835	1.4	920	1.7	1014	2.0	1100	2.3	1167	2.6
50	4630	735	1.2	835	1.4	920	1.7	1014	2.0	1100	2.3	1167	2.6
	4873	755	1.3	850	1.5	935	1.8	1027	2.1	1100	2.5	1175	2.7
	5144	805	1.5	882	1.8	975	2.0	1050	2.4	1135	2.7	1200	3.0
	5447	842	1.8	920	2.0	1010	2.4	1083	2.8	1155	2.9	1220	3.4
	5787	882	2.0	968	2.4	1042	2.7	1114	3.0	1187	3.4	1246	3.8
55	5093	800	1.5	883	1.8	977	2.0	1054	2.4	1120	2.7	1200	3.0
	5361	825	1.6	905	1.9	1000	2.3	1058	2.6	1137	3.0	1208	3.3
	5658	842	1.9	930	2.2	1009	2.5	1084	2.9	1155	3.2	1220	3.5
	5991	883	2.1	965	2.5	1041	2.8	1109	3.2	1187	3.6	1250	3.9
	6366	940	2.6	1017	2.9	1100	3.3	1160	3.7	1225	3.9	1290	4.4
65	6019	623	1.4	711	1.8	792	2.3	864	2.6	928	3.1	1000	3.5
	6335	650	1.6	729	2.1	800	2.4	871	2.9	939	3.3	1000	3.8
	6687	692	1.9	754	2.3	823	2.7	900	3.2	958	3.7	1020	4.0
	7081	714	2.2	792	2.6	858	3.0	914	3.6	977	4.1	1036	4.5
	7523	750	2.6	810	3.0	884	3.5	940	4.0	1000	4.4	1100	5.7
75	6944	710	2.1	785	2.6	854	3.0	920	3.2	979	3.8	1040	4.4
	7310	736	2.5	800	2.9	864	3.3	926	3.8	987	4.2	1053	4.5
	7715	775	2.9	843	3.3	912	3.8	960	4.2	1020	4.9	1073	4.7
	8170	800	3.3	860	3.8	931	4.2	976	4.4	1033	5.2	1080	5.8
	8681	838	3.5	912	4.3	959	4.6	1017	4.5	1066	6.0	1117	6.5
85	7870	671	2.9	732	3.5	783	4.2	856	5.0	917	5.6	961	6.3
	8285	705	3.4	770	4.0	820	4.7	890	5.6	950	6.3	995	7.1
	8785	755	4.2	805	4.9	870	5.6	920	6.5	970	7.3	1020	8.3
	9295	790	4.9	840	5.6	895	6.3	950	7.3	990	8.1	1050	8.9
	9838	820	5.7	880	6.5	940	7.3	980	8.1	1030	9.1	1070	9.9
100	9259	770	4.7	830	5.4	890	6.1	940	7.1	990	7.8	1040	8.9
	9747	800	5.4	860	5.9	910	6.9	970	7.7	1005	8.7	1060	9.5
	10288	830	5.9	890	6.7	940	7.5	990	8.5	1040	9.5	1080	10.1
	10893	890	7.1	930	7.9	980	8.9	1020	9.7	1070	10.5	1100	11.6
	11574	930	8.5	970	9.2	1010	10.0	1060	11.0	1100	11.7	1140	13.1

Notes:

1. The capacities shown include the internal resistance of the basic burner/fan unit. Resistance of ductwork, inlet cowls, filter boxes, dampers etc. must be calculated and totalled to determine the total external static pressure.
2. For higher external static pressures consult head office.
3. Performance is based on standard air (density .075 lb. per cubic foot, 70° F, 29.92" hg. bar). Horsepower data includes drive losses.

Fan Chart 2

TDM MODEL	VOLUME FLOW CFM	TOTAL EXTERNAL STATIC PRESSURE IN INCHES OF WATER COLUMN											
		0.25		0.5		0.75		1.0		1.25		1.5	
		RPM	BHP	RPM	BHP	RPM	BHP	RPM	BHP	RPM	BHP	RPM	BHP
125	11574	620	3.8	690	4.3	730	5.1	795	5.8	840	6.7	890	7.5
	12183	650	4.2	710	5.0	760	5.7	815	6.5	870	7.4	910	8.2
	12860	680	4.7	740	5.5	790	6.3	830	7.2	890	8.1	930	8.9
	13616	700	5.6	760	6.3	810	7.2	860	8.2	910	9.0	950	9.7
	14467	750	6.8	800	7.8	850	8.7	900	9.5	940	9.9	990	10.5
150	13890	710	6.1	760	6.8	820	7.7	870	8.4	915	9.4	960	10.2
	14620	750	6.9	800	7.7	850	8.7	900	9.4	940	10.4	985	11.4
	15432	790	8.0	830	8.8	880	9.7	930	10.8	970	11.5	1010	12.6
	16340	820	9.4	870	10.3	920	11.4	960	12.4	1000	13.2	1040	14.2
	17361	870	11.5	920	12.4	960	13.5	1000	14.1	1030	15.2	1070	16.3
175	16204	810	8.9	860	10.0	950	10.8	950	12.0	990	12.8	1030	13.6
	17057	840	10.3	890	11.4	930	12.3	980	13.1	1010	14.1	1050	14.9
	18004	900	12.1	930	13.0	970	14.0	1010	14.9	1050	16.3	1070	17.1
	19063	940	14.1	980	14.8	1015	15.8	1050	17.3	1090	18.5	1120	19.8
	20254	1000	17.0	1020	18.2	1070	19.4	1105	20.4	1130	22.0	1160	23.3
200	18518	650	7.5	701	8.6	775	9.8	810	10.9	870	12.3	915	13.3
	19493	690	8.6	740	9.9	800	10.6	850	12.6	900	14.0	930	14.8
	20576	725	10.5	775	11.6	828	12.9	876	14.0	926	15.1	964	16.6
	21786	766	12.4	823	13.7	861	14.7	914	16.3	953	17.4	990	18.6
	23148	810	14.2	860	15.7	900	17.0	940	18.2	985	19.6	1020	21.1
250	23148	810	14.2	860	15.7	900	17.0	940	18.2	985	19.6	1020	21.1
	24366	840	16.5	890	17.9	920	19.3	970	20.5	1010	21.9	1040	23.3
	25720	890	18.9	930	20.5	970	21.8	1010	23.2	1040	24.9	1080	26.6
	27723	940	22.3	970	24.2	1015	25.7	1055	27.3	1090	28.9	1120	30.5
	28935	1000	27.0	1025	28.1	1070	29.9	1100	32.1	1130	34.0	1160	35.7
275	25462	590	9.5	625	10.1	680	12.6	725	15.0	760	15.8	800	17.4
	26803	610	10.7	650	12.6	700	14.2	740	15.8	780	17.3	820	18.9
	28292	640	12.6	680	14.5	720	15.8	775	18.9	800	20.0	840	21.1
	29956	675	15.3	715	17.1	750	18.9	800	20.5	830	22.1	865	23.7
	31828	710	18.3	750	20.6	780	22.1	825	23.7	850	25.3	875	26.2
300	27778	600	13.2	650	14.7	690	16.9	730	18.8	770	21.2	820	23.0
	29240	620	14.3	670	16.7	710	18.8	760	20.6	790	23.0	830	25.4
	30864	660	17.6	695	19.7	730	21.8	780	23.6	815	25.8	860	27.6
	32680	695	20.3	720	22.4	770	24.5	800	26.6	840	28.1	885	30.3
	34722	730	24.2	760	26.2	800	27.8	835	30.2	870	32.1	900	34.1
350	32407	680	19.3	715	21.8	750	24.1	795	25.9	830	27.8	870	29.8
	34113	705	22.4	740	24.3	780	26.6	825	28.5	850	30.3	890	32.3
	36008	740	26.3	780	28.2	830	30.2	850	32.3	870	34.6	910	37.0
	38126	780	30.1	820	32.2	850	34.6	880	37.0	915	39.3	940	41.7
	40509	820	36.2	860	38.6	890	40.9	930	43.2	950	44.9	990	48.6
400	37037	770	28.8	810	30.8	840	32.9	870	35.1	900	36.9	940	37.7
	38987	800	32.2	830	34.6	860	37.0	900	36.7	920	41.2	960	42.9
	41152	830	37.8	860	40.1	900	42.5	925	44.2	950	46.5	980	49.3
	43573	870	43.3	910	46.0	930	48.3	960	51.5	980	53.5	1020	56.7
	46297	920	51.8	950	55.1	970	57.6	1008	59.8	1020	63.7	1050	65.9

Notes:

1. The capacities shown include the internal resistance of the basic burner/fan unit. Resistance of ductwork, inlet cowls, filter boxes, dampers etc. must be calculated and totalled to determine the total external static pressure.
2. For higher external static pressures consult head office.
3. Performance is based on standard air (density .075 lb. per cubic foot, 70° F, 29.92" hg. bar). Horsepower data includes drive losses.



TDM Series Indirect Fired Heaters

Engineering Ratings Chart

Model Number	25	35	40	50	55	65	75	85	100	125	150	175	200	250	275	300	350	400	500	600
Input Capacity (1000 btu/hr)	312	437	500	625	687	812	937	1062	1250	1562	1875	2187	2500	3125	4347	3750	4375	5000	6250	7500
Output Capacity (1000 btu/hr)	250	350	400	500	550	650	750	850	1000	1250	1500	1750	2000	2500	2750	3000	3500	4000	5000	6000
Main Supply Fans (Quantity/Size)	2/12	2/12	2/12	2/12	2/12	2/15	2/18	2/18	2/18	3/18	3/18	3/18	3/18	3/18	3/20	3/22	3/22	3/22	3/25	3/25
Discharge Heads (Quantity/Size)	2/15	2/15	3/15	3/15	3/15	4/15	4/15	4/15	4/15	4/18	4/18	4/18	5/18	5/18	6/18	7/18	7/18	7/18	-	-
Nominal Air Volume (CFM)	2723	3813	4357	5447	5991	7081	8170	9295	10893	13616	16340	19063	21786	27723	29956	32680	38126	43573	54466	65360
Throw in Feet w/90° Nozzles	74	96	78	98	107	95	110	124	147	153	183	215	195	230	215	209	244	269	-	-
Throw in Feet w/45° Nozzles	83	116	87	110	120	106	123	140	165	171	205	238	218	248	239	234	274	298	-	-
Induced Draft Fan Motor HP	1/3	1/3	1/3	1/3	1/3	1/3	1/3	1/2	1/2	3/4	3/4	1 1/2	1 1/2	2	2	3	3	3	3	5
Standard Gas Burner Motor HP	1/8	1/8	1/8	1/4	1/3	1/3	1/3	1/3	1/3	1/2	1/2	1/2	1/2	1	1	1	1 1/2	2	3	5
Standard Oil Burner Motor HP	1/2	1/2	1/2	1/2	1/2	1/2	1/2	1/2	1/2	1/2	3/4	1	1	2	3	3	5	5	-	-
Recommended Stack Diameter (Inches)	8	8	8	8	8	10	10	10	10	12	12	12	12	12	14	14	14	14	16	16
Primary Combustion Chamber (Gauge)	16	16	16	16	16	16	16	16	14	14	14	14	14	14	14	14	14	14	14	14
Secondary Tubes (Gauge)	16	16	16	16	16	16	16	16	16	16	16	16	16	16	16	16	16	16	14	14
Natural Gas Conn. with 7" W.C. Inlet Pressure (Inches N.P.T)	3/4	3/4	1	1	1	1 1/4	1 1/4	1 1/4	1 1/2	1 1/2	2	2	2	2	2 1/2	2 1/2	3	3	3	3
Natural Gas Conn. with 14" W.C. and Over Inlet Press. (Inches N.P.T)	3/4	3/4	3/4	3/4	1	1	1	1	1	1 1/4	1 1/2	1 1/2	1 1/2	2	2	2	2	2 1/2	2 1/2	2 1/2
Filter Box Initial Pressure Drop at Nominal CFM (Inches W.C.)	.06	.12	.07	.11	.13	.10	.14	.08	.11	.11	.15	.21	.11	.17	.15	.14	.18	.24	.22	.30
Mixing Box Pressure Drop at Nominal CFM (Inches W.C.)	.03	.06	.05	.07	.09	.06	.08	.11	.14	.08	.11	.15	.08	.14	.12	.10	.14	.18	.11	.18
Discharge Heads Pressure Drop at Nominal CFM (Inches W.C.)	.17	.34	.19	.30	.36	.27	.36	.46	.63	.38	.55	.74	.63	1.02	.83	.70	.95	1.24	-	-

Note: The above chart is a guide. In order to maintain our policy of continuous product improvement, we reserve the right to make changes without notice.

Specification

TDM Specification

SYSTEM:

PREPARED FOR:

JOB NAME:

DATE:

SCOPE

The Indirect Gas Fired unit shall be Model TDM _____ and supplied by Temprite Industries.

The unit shall be factory fabricated, assembled, wired and tested prior to shipment in accordance with the specification and equipment schedule.

The unit will include all components herein and as shown on the drawings. Alternate equipment, equal in design, construction, performance and capacity to unit(s) specified, must be shown with price deduct/add, if any. Approval of alternate equipment will be subject to review of shop drawings.

The unit shall be CGA/ETL approved and capable of following performance:

Airflow Rate:	_____	Scfm (Acfm)
Entering Air Temperature:	_____	°F. (°C)
Leaving Air Temperature:	_____	°F. (°C)
External Static Pressure:	_____	" w.c.
Main Fan Motor Size:	_____	Hp
Induced Draft Fan Motor Size:	_____	Hp
Heat Output:	_____	Btuh
Heat Input:	_____	Btuh

CASING

The unit casing is be panel construction from 16 gauge galvanized steel, suitably reinforced to ensure rigidity.

Panels shall be fastened with cadmium plated neoprene grommets metal screws (sheet metal screws and/or pop rivets are not acceptable) and be removable for servicing.

All panels shall be factory sealed with butyl tape between mating panels and externally caulked at all seams prior to painting.

The unit shall have an integral milled channel base complete with lifting lugs.

The casing enclosing the heat exchanger shall be of double wall construction with a galvanized steel inner wall serving as a radiation shield. Radiation and transmission losses shall not exceed 1 1/2% of the rated output. This section shall be insulated with 1", 1 1/2 lb. density mineral wool.

Specification

The fan section shall be insulated with 1", 1 1/2 lb. density fabric faced fiberglass mechanically secured to the walls with welded pins at 12" centers horizontally and vertically. All joints shall be taped or sealed.

The underside of the unit (under the floor) shall be insulated with 1", 1 1/2 lb. density foil faced fiberglass, mechanically secured to the floor with welded pins at 12" centers horizontally and vertically. All joints shall be taped or sealed.

The unit shall have a weather enclosure which is the full height of the unit. The enclosure will be complete with hinged access doors, captive screws and handles.

An inlet cowl and birdscreen will be provided. The inlet velocity to the cowl will be designed not to exceed 500 fpm.

When split for shipping, the unit splits will be framed with heavy structural angle to form flanges with drilled notch holes at 12" maximum spacing. Factory fabricated mechanically fastened 1/2" thick gaskets will be provided for flanges at all shipping splits.

The entire unit shall be brushed or scraped to remove any dirt, dust or other foreign substances. The unit will be primed with a vinyl wash and finish coated with a heat resistant alkyd enamel.

Hinged access doors with cadmium plated piano type hinges shall be supplied to allow physical entry to all sections requiring inspection and periodic maintenance. Access doors shall be complete with 1" thick insulation, interior metal liner, captive screws and handles.

FAN SECTION

The fan section shall be downstream of the heat exchanger to ensure constant air volume at the specified discharge temperature. The fan(s) shall be centrifugal AMCA rated forward curved statically and dynamically balanced. The fan(s) shall be double width, double inlet with motor and drives in the air stream.

The fan is to be mounted on a heavy duty, turned and ground solid steel shaft designed with its maximum operating speed not exceeding 75% of its first critical speed. The bearings are to be of the pre-lubricated, self aligning type. Drives have a capacity 25% greater than the motor horsepower and a minimum of two belts. Up to 7.5 HP, the motor sheaves shall be of the adjustable pitch type. Motors shall be rated for fan duty, (ODP) (TEFC), T-frame and _____ volt, _____ cycle, _____ phase. The fan motor shall be mounted on an adjustable base and wired in flexible conduit to the control panel.

The fan wheel, shaft, drives, and motor assembly shall be electrically balanced as a complete assembly in the factory.

INDIRECT GAS FIRED SECTION

The heat exchanger shall be rated at a minimum 80% efficiency at rated output. The flue gas travel shall be of four-pass design, with no internal baffles. The primary heat transfer surface and header shall be of 409 stainless steel; the secondary heat transfer surface shall be (steel boiler tube) (409 stainless steel). The heat exchanger design shall permit unrestricted lateral and peripheral expansion during the heating and cooling cycle. The surface temperature of the heat exchanger shall not exceed 75% of its scaling temperature when operating at rated capacity. A pressure relief door complete with an observation window to view the complete flame and pilot shall be provided.

An integrally mounted, heavy duty, radial blade induced draft fan c/w motor shall be provided. The induced draft fan shall be equipped with a manual damper complete with locking quadrant to ensure proper draft, rated efficiency and extended heat exchanger performance.

Specification

The burner shall fire natural gas and be arranged for full modulation with low fire start and a _____ turndown ratio. The factory wired and piped valve train shall be mounted on the unit and be complete with:

- an (low pressure) appliance regulator
- automatic main gas shut-off valve
- auxiliary main gas shut-off combination modulating valve
- main manual test firing shut-off valve
- pilot manual shut-off valve
- pilot pressure regulator
- pilot automatic shut-off valve
- pilot manual test firing shut-off valve

ELECTRICAL CONTROLS

A NEMA 1 control panel complete with hinged access door shall be mounted on the unit and wired. All control components are to be labelled and individually wired to a numbered terminal strip to aid in servicing. All wiring shall be color coded and number tagged at each end to match the control diagram supplied. Full operating and maintenance instructions shall accompany each unit. All wiring between the controls and valves shall be run in flexible conduit. The control system shall include but not be limited to the following components required for automatic operation:

- main disconnect switch
- control circuit transformer
- fan motor starters, overloads and subcircuit fuses
- control circuit fuses
- control relays
- electronic flame relay complete with alarm contacts
- induced draft fan air proving differential switch
- high limit switch
- automatic/manual fan switch
- heavy duty ignition transformer

All controls are to be mounted in the control enclosure and wired to a numbered terminal strip. All wiring shall be colour coded with numbers tagged at each end to match the circuit diagram supplied with the unit. Full operating and maintenance instructions shall accompany each unit.

COOLING COIL SECTION

Cooling coil section shall be a minimum of 36" deep in direction of airflow and located downstream of the filters and upstream of the heat exchanger. Coils to have slide frames and heavy gauge galvanized steel blank off sheets. Coils to slide into unit through a removable end panel. Troughs and down spouts will be supplied where required for coil banks more than one high.

Chilled water coils with copper tubes, aluminum fins and galvanized steel casing. Headers to be non-ferrous with vents, drains and suitable for 200 psi working pressure. Maximum air velocity across the face of the coil shall not exceed 500 fpm.

Specification

Provide drain pan under the cooling coil and downstream of the coil to collect all condensation. Provide a minimum of two drain pans where cooling coils are stacked complete with piped down drain. Drain pan shall be galvanized steel construction.

FILTERS

Air filters shall be 2" medium efficiency, pleated, disposable type. Filter media shall be of the non-woven cotton fabric and have an average efficiency of 25 - 30% on Ashrae Test Standard 52-76. Filters shall have a rated air velocity of 500 FPM and a final resistance of 1.0" w.g. Filters shall be rated Class 2 by Underwriter's Laboratories and each product shall bear the U.L.C. label indicating class and issue number. Face velocity shall not exceed those shown on the schedule.

The filters shall be mounted in the main body of the unit. Filters mounted on the inlet cowl are not acceptable.

DAMPERS

The unit will be complete with a motorized discharge damper with a 16 gauge galvanized steel frame. Blades shall be rolled formed, triple V-groove 16 gauge galvanized steel, maximum 6" wide. Axles shall be 1/2" plated steel hex. Bearings shall be molded synthetic and linkage outside of the air stream. Blade edge seals shall be extruded dual vinyl. The damper and damper motor shall be mounted inside the unit casing.

START UP

Start up to be performed by a factory trained technician and to include testing the controls and ensuring the proper operation of all the unit functions. Any wiring or piping connections required due to the unit being split in sections (including remote panels) is the responsibility of the installing contractor. Start up will not include any air balancing required due to changes in external static pressures.