

Typical Gas Piping Layout

Schematic Component Diagrams

C000148

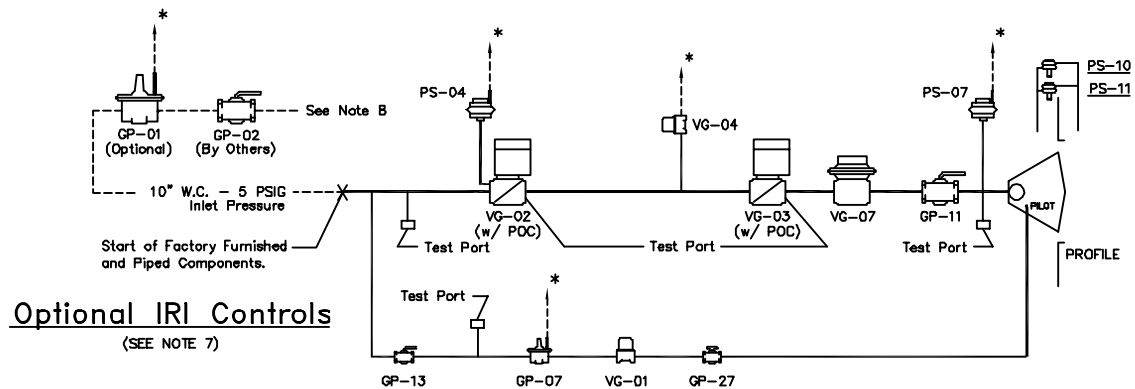
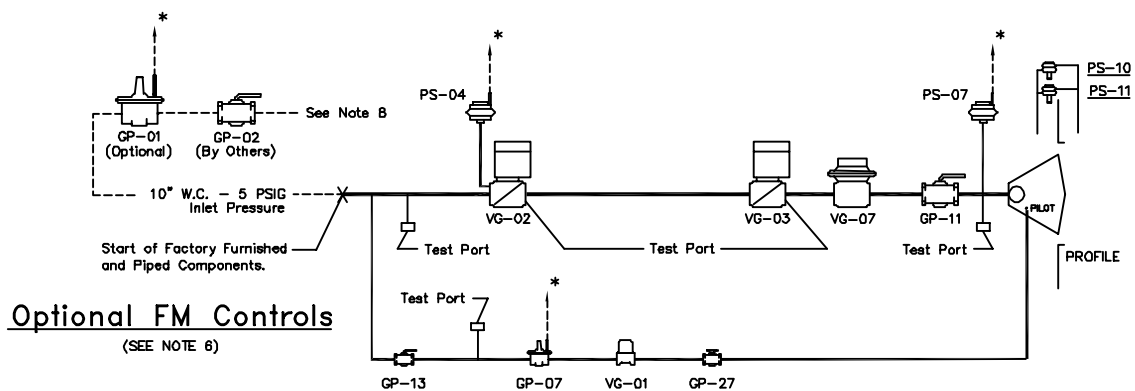
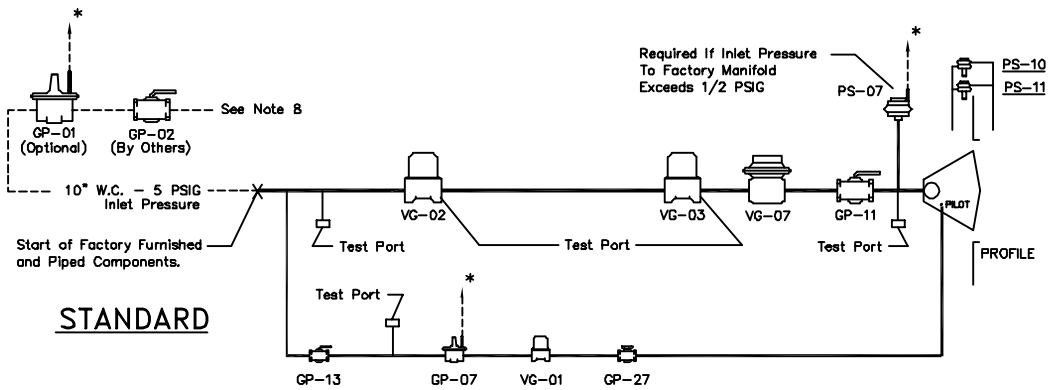

COMPONENT IDENTIFICATION

- GP-01 HIGH GAS PRESSURE REGULATOR
- GP-02 MAIN GAS SHUT-OFF VALVE
- GP-09 PILOT GAS PRESSURE REGULATOR
- GP-11 MAIN TEST FIRING SHUT-OFF VALVE
- GP-13 PILOT GAS SHUT-OFF VALVE
- GP-27 ORIFICED NEEDLE VALVE
- VG-01 PILOT GAS VALVE
- VG-02 MAIN GAS VALVE
- VG-03 AUXILIARY GAS VALVE
- VG-04 NORMALLY OPEN VENT VALVE
- VG-07 MODULATING VALVE
- PS-04 LOW GAS PRESSURE SWITCH
- PS-07 HIGH GAS PRESSURE SWITCH
- PS-10 HIGH VELOCITY PRESSURE SWITCH
- PS-11 LOW VELOCITY PRESSURE SWITCH

NOTES:

1. Vent limiting devices provided wherever possible, when venting is required* the venting to outside is by others on indoor units.
2. Units with 900 MBH and less use a pressure regulator (not shown) for high fire setting.
3. For inlet pressures under 10" W.C. - Please consult factory.
4. 3,300 MBH and above will require a minimum inlet pressure of 1 PSIG. For inlet pressures under 1 PSIG - Please consult factory.
5. Units that are listed to the Z83.4 standard (100% make-up air) carry both ETL and CETL approvals.
6. Standard manifold meets FM requirements for inputs under 2,500 MBH for ETL listed units.
7. Standard manifold meets IRI requirements for ETL listed units.
8. High gas pressure regulator required if inlet pressure exceeds 1/2 PSIG for inputs up to and including 900 MBH or inlet pressures over 5 PSIG for inputs greater than 900 MBH.